

## Vue éclatée modèle CG 47EY(T) - débroussailleuse

Serial n° xx

ITEM N°	CODE N°	DESCRIPTION	N° Used	x	x	x	x	x	x	x
		<b>MODEL:CG47EY</b>								0
		B31-01 CYLINDER/PISTON/CRANK								0
006	157-11666-90	SPARK PLUG CAP ASS'Y	1							0 *07
007	255-04200-20	SPARK PLUG RUBBER COVER	1							0 47185
008	018-06540-21	SPARK PLUG BPMR6A	1							0
011	001-0422U-90	CYLINDER SET	1							0
012	994-61050-184	HEX. HOLE BOLT 5X18/S	4							0
014	017-04220-21	CYLINDER GASKET	1							0
015	041-04090-21	PISTON RING	2							0
016	030-0422U-90	PISTON SET	1							0
017	037-10100-20	PISTON PIN	1							0
018	039-01000-20	PISTON PIN CIRCLIP	2							0
020	036-04090-20	PISTON PIN COLLAR	2							0
021	046-04220-80	CRANK SHAFT COMP.	1							0
022	999-62101-480	NEEDLE BEARING, 2X8.8	1							0
031	068-02000-20	WOOD-RUFF KEY 3X13X5	1							0
		B31-02 CRANK CASE								0
019	991-11100-013	SMALL NUT 10	1							0
026	072-04220-91	CRANK CASE ASS'Y	1							0
027	090-04200-21	CRANK CASE GASKET	1							0
028	999-66152-564	OIL SEAL UD15257	2							0
029	999-61620-200	BALL BEARING #6202, 35MM/OD	2							0
030	070-02401-20	CRANK SHAFT WASHER 15.2X22	2							0
032	071-02007-23	CRANK SHAFT SHIM 0.20	V							0
032	071-02007-24	CRANK SHAFT SHIM 0.30	V							0
036	990-53060-453	HEX HOLE BUTTON SCREW 6X45	2							0
038	990-53060-353	HEX. HOLE BOLT 6X35	2							0
045	992-10060-062	S.WASHER 6	4							0
046	991-01060-013	NUT 6	1							0
047	894-01401-20	OUTER RECEIVER	1							0
051	155-20537-80	MAGNET ROTOR COMP.	1							0
052	992-00100-011	SMALL WASHER 10	1							0
054	991-11100-011	NUT 10	1							0
055	167-20548-80	IGNITION COIL	1							0
056	994-14050-181	SCREW 5X18/S	2							0
058	992-00050-011	SMALL WASHER 5	2							0
069	203-06590-20	GROMMET	1							0
070	191-04280-90	LEAD WIRE ASS'Y	1							0
		B31-03 ENGINE-1								0
027	655-04200-20	FUEL TANK CUSHION RUBBER	2							0
031	403-04220-21	INLET MANIFOLD GASKET	1							0
032	404-0422U-90	CARB. INSULATOR SET	1							0
033	402-01740-20	CARBURETOR GASKET	1							0
045	455-0422W-90	CARBURETOR ASS'Y	1							0
049	994-16050-241	SCREW 5X24WS	2							0
051	495-04200-20	CHOKE LEVER	1							0
052	700-02504-09	FUEL PIPE 2.5X4X90	2							0
053	991-11100-013	SMALL NUT 10	1							0
054	992-20100-010	INNER TOOTHED WASHER 10	1							0

ITEM N°	CODE N°	DESCRIPTION	N° Used	x	x	x	x	x	x	x
		<b>MODEL:CG47EY</b>								0
055	422-25030-80	PRIMING PUMP COMP.	1							0
063	223-01251-90	FUEL PIPE ASS'Y 3X5X230	1							0
064	680-00731-20	CLIP, 6.3 DIA.	1							0
065	675-01630-90	PUMP FILTER BODY ASS'Y	1							0
066	591-04220-21	FUEL TANK, VERMILION	1							0
068	534-32710-20	RETURN GROMMET	1							0
070	595-00093-90	TANK CAP D ASS'Y ORANGE	1							0
076	603-04201-20	TANK HOLDING BAND	1							0
077	652-04201-20	CUSHION RUBBER	1							0
078	994-15050-162	SCREW 5X16/PS	2							0
096	626-32550-20	TANK CAP CHAIN	1							0
		B31-04 ENGINE-2								0
001	738-04220-20	MUFFLER PROTECTOR	1							0
002	994-15050-122	SCREW 5X12/PS	1							0
003	994-61050-124	HEX. HOLE BOLT 5X12S	1							0
004	992-01050-061	WASHER 5	1							0
005	990-53060-653	HEX. HOLE BUTTON SCREW 6X65	2							0
006	992-01060-011	WASHER 6	2							0
007	704-0422S-90	MUFFLER SET	1							0
009	751-04200-20	MUFFLER SPECIAL GASKET	1							0
010	721-0423Z-90	TAIL PIPE SET, SPARE	1							0
011	994-14040-081	SCREW 4X8/S	2							0
014	737-04230-20	MUFFLER GASKET	1							0
016	133-04230-20	HEAT SHIELD	1							0
023	994-15050-182	SCREW 5X18/PS	2							0
025	653-04200-20	TANK BRACKET	1							0
026	655-06100-20	FUEL TANK CUSHION RUBBER	2							0
081	359-10112-20	CLUTCH WASHER B	2							0
082	290-04270-80	CLUTCH ARM	2							0
083	342-04270-20	CLUTCH SPRING	1							0
084	992-04100-030	WAVE WASHER 10	2							0
085	357-0136U-20	CLUTCH STEP BOLT	2							0
		B31-05 RECOIL STARTER								0
000	762-04220-90	RECOIL STARTER BODY ASS'Y	1							0
001	772-04220-80	RECOIL STARTER BODY COMP.	1							0
002	769-04220-20	STARTER ROPE REEL	1							0
003	779-04220-20	RECOIL SPRING	1							0
009	783-04270-20	STARTER ROPE	1							0
012	835-04220-20	STARTER HANDLE CAP	1							0
014	785-04220-20	STARTER HANDLE	1							0
017	839-04220-20	SET SCREW	1							0
019	788-0162V-20	STARTER PAWL	1							0
020	993-55050-000	STOP RING E-5	1							0
024	790-0162V-20	STARTER PAWL SPRING	1							0
025	798-04220-90	STARTER PULLEY	1							0
024	994-15050-252	SCREW 5X25PS	2							0
		B31-06 AIR CLEANER								0
036	423-04270-20	CLEANER BODY	1							0
037	659-00801-20	COLLAR 5.8	2							0
038	476-0422U-80	BLOW OVER CHECK BOARD COMP.	1							0
039	446-04270-20	CLEANER ELEMENT	1							0
041	424-04270-90	CLEANER COVER ASS'Y	1							0
042	450-04072-20	COVER FIXING BOLT	1							0

ITEM N°	CODE N°	DESCRIPTION	N° Used	x	x	x	x	x	x	x
		<b>MODEL:CG47EY</b>								0
043	990-11050-601	SCREW 5X60	2							0
044	992-10050-012	S.WASHER 5	2							0
		B31-07 CARBURETOR								0
001	514-25001-20	SET SCREW	1							0
002	575-25012-20	PUMP BODY	1							0
003	577-25012-20	PUMP GASKET	1							0
004	576-25012-20	PUMP DIAPHRAGM	1							0
005	578-25007-20	INLET SCREEN	1							0
017	463-25012-20	IDLE ADJUST SPRING	1							0
018	462-25006-20	IDLE ADJUST SCREW	1							0
022	603-25012-20	NEEDLE VALVE #	1							0
023	477-25307-20	VALVE SPRING	1							0
024	473-25012-20	CONTROL LEVER	1							0
025	605-25001-20	HINGE PIN	1							0
026	546-25001-20	HINGE PIN SET SCREW	1							0
027	475-25032-20	DIAPHRAGM GASKET	1							0
028	474-25032-80	METERING DIAPHRAGM COMP.	1							0
029	454-25032-80	AIR PURGE COMP.	1							0
030	476-25032-20	DIAPHRAGM COVER	1							0
031	548-25016-20	SET SCREW	4							0
		B31-08 FAN CASE								0
001	289-04308-80	CLUTCH SHAFT COMP.	1							0
003	999-61620-201	BALL BEARING #620ZZ, 35MM/OD	1							0
004	993-51035-002	STOP RING C-35, INNER	1							0
005	993-50015-002	STOP RING C-15, OUTER	1							0
015	990-54060-253	HEX.HOLE BOLT 6X25	1							0
066	112-04280-22	FAN CASE OR	1							0
067	994-14060-202	SCREW 6X20/S	4							0
		B31-09 OPERATION PIPE								0
001	343-38101-20	DRIVE SHAFT, 1552L	1							0
002	341-37861-80	DRIVE SHAFT PIPE	1							0
003	347-37100-90	BUSHING ASS'Y	5							0
011	512-37861-80	KNOB BOLT	1							0
013	506-37861-20	HANDLE BRACKET A	1							0
014	507-37861-20	HANDLE BRACKET B	1							0
015	522-37861-20	SUPPORT HOLDER	1							0
016	521-37861-80	HANDLE SUPPORT COMP.	1							0
017	315-37861-20	SPECIAL NUT M6X1.0	1							0
018	326-37180-21	ANTI-VIBE RUBBER	4							0
020	991-87060-001	NUT 6 UPS-P	1							0
021	990-54060-303	HEX. HOLE BOLT 6X30	1							0
022	198-3332A-20	CORD CLAMP	1							0
063	165-37861-20	HANDLE GRIP	1							0
074	198-37861-21	CORD CLAMP	2							0
086	746-37180-91	SHOULDER BELT ASSY	1							0
092	501-37861-21	HANDLE	1							0
		B31-010 THROTTLE LVER								0
084	164-07099-00	PROTECTION TUBU 990L	1							0
095	870-37180-91	THROTTLE LEVER 20	1							0
098	253-38400-20	SAFETY LEVER	1							0
100	832-38400-20	RETURN SPRING	1							0
101	880-38401-20	THROTTLE LEVER	1							0
106	993-46040-202	SCREW 4X20, BLACK	2							0

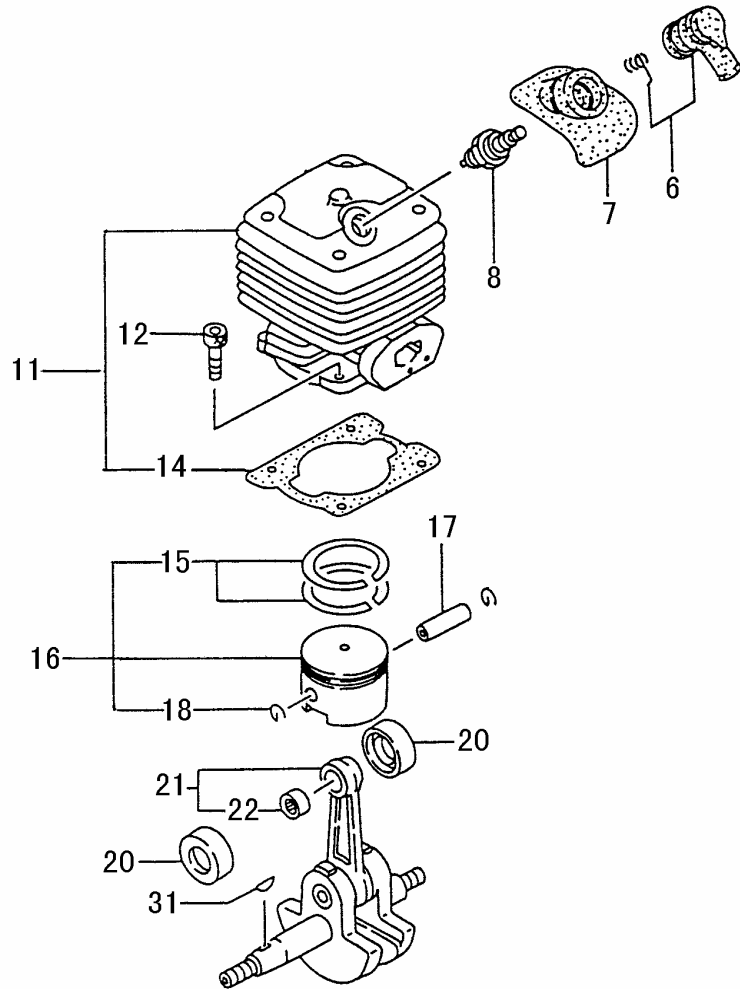

**B31-01****CG40EY(T) CYLINDER/PISTON/CRANK SHAFT**

REF. NUMBER	PARTS NUMBER	DESCRIPTION	Q'TY	SERIAL NUMBER
006	157-11666-90	SPARK PLUG CAP ASS'Y	1	
007	255-04200-20	SPARK PLUG RUBBER COVER	1	
008	018-06540-21	SPARK PLUG BPMR6A	1	
011	001-0422U-90	CYLINDER SET	1	
012	994-61050-184	HEX. HOLE BOLT 5X18/S	4	
014	017-04220-21	CYLINDER GASKET	1	
015	041-04090-21	PISTON RING	2	
016	030-0422U-90	PISTON SET	1	
017	037-10100-20	PISTON PIN	1	
018	039-01000-20	PISTON PIN CIRCLIP	2	
020	036-04090-20	PISTON PIN COLLAR	2	
021	046-04220-80	CRANK SHAFT COMP.	1	
022	999-62101-480	NEEDLE BEARING, 2X8.8	1	
031	068-02000-20	WOOD-RUFF KEY 3X13X5	1	

**B31-02 CG47EY(T) CRANK CASE**

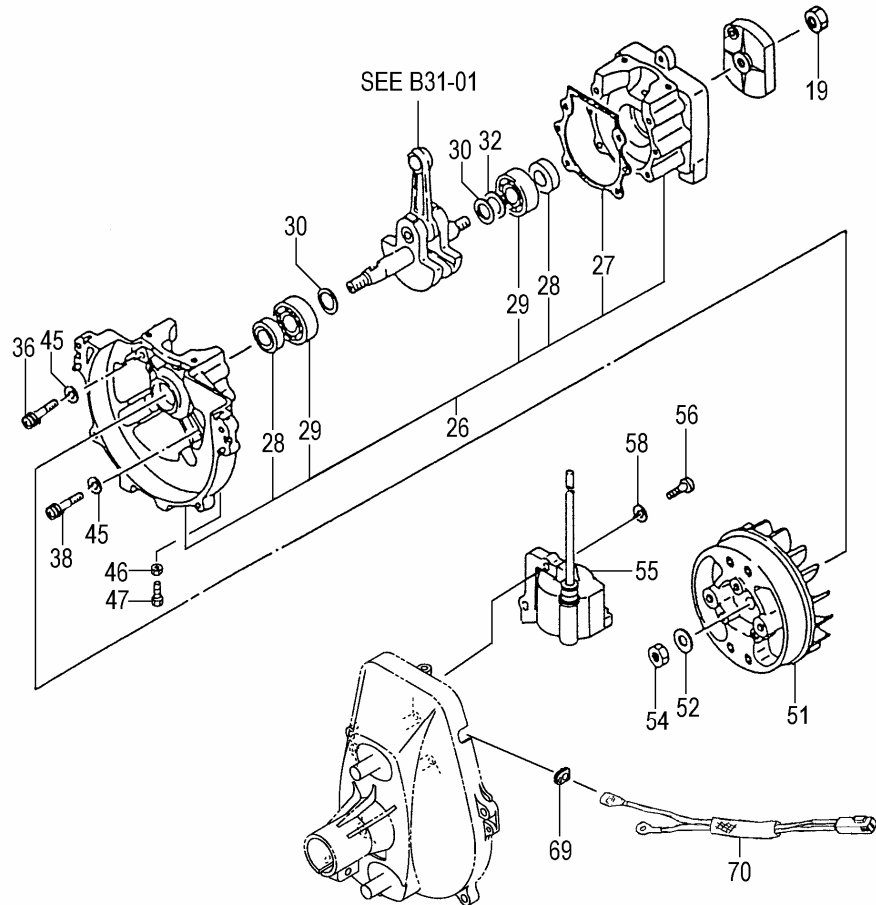

REF. NUMBER	PARTS NUMBER	DESCRIPTION	Q'TY	SERIAL NUMBER
019	991-11100-013	SMALL NUT 10	1	
026	072-04220-91	CRANK CASE ASS'Y	1	
027	090-04200-21	CRANK CASE GASKET	1	
028	999-66152-564	OIL SEAL UD15257	2	
029	999-61620-200	BALL BEARING #6202, 35MM	2	
030	070-02401-20	CRANK SHAFT WASHER 15.2	2	
032	071-02007-23	CRANK SHAFT SHIM 0.20	V	
032	071-02007-24	CRANK SHAFT SHIM 0.30	V	
036	990-53060-453	HEX HOLE BUTTON SCREW	2	
038	990-53060-353	HEX. HOLE BOLT 6X35	2	
045	992-10060-062	S.WASHER 6	4	
046	991-01060-013	NUT 6	1	
047	894-01401-20	OUTER RECEIVER	1	
051	155-20537-80	MAGNET ROTOR COMP.	1	
052	992-00100-011	SMALL WASHER 10	1	
054	991-11100-011	NUT 10	1	
055	167-20548-80	IGNITION COIL	1	
056	994-14050-181	SCREW 5X18/S	2	
058	992-00050-011	SMALL WASHER 5	2	
069	203-06590-20	GROMMET	1	
070	191-04280-90	LEAD WIRE ASS'Y	1	

**B31-03 CG47EY(T) ENGINE-1**

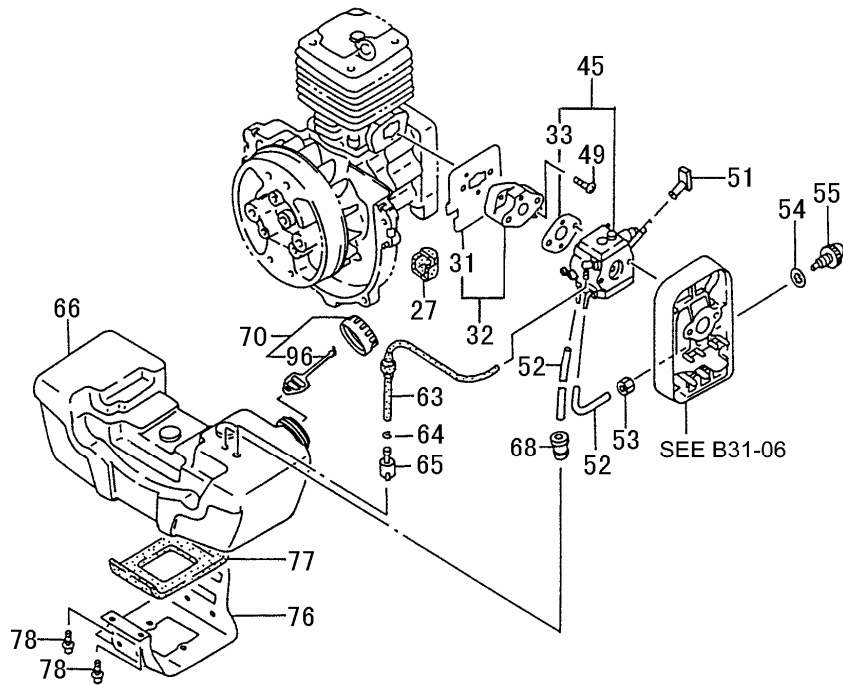

REF. NUMBER	PARTS NUMBER	DESCRIPTION	Q'TY	SERIAL NUMBER
027	655-04200-20	FUEL TANK CUSHION RUBBER	2	
031	403-04220-21	INLET MANIFOLD GASKET	1	
032	404-0422U-90	CARB. INSULATOR SET	1	
033	402-01740-20	CARBURETOR GASKET	1	
045	455-0422W-90	CARBURETOR ASS'Y	1	
049	994-16050-241	SCREW 5X24WS	2	
051	495-04200-20	CHOKE LEVER	1	
052	700-02504-09	FUEL PIPE 2.5X4X90	2	
053	991-11100-013	SMALL NUT 10	1	
054	992-20100-010	INNER TOOTHED WASHER 1	1	
055	422-25030-80	PRIMING PUMP COMP.	1	
063	223-01251-90	FUEL PIPE ASS'Y 3X5X230	1	
064	680-00731-20	CLIP, 6.3 DIA.	1	
065	675-01630-90	PUMP FILTER BODY ASS'Y	1	
066	591-04220-21	FUEL TANK, VERMILION	1	
068	534-32710-20	RETURN GROMMET	1	
070	595-00093-90	TANK CAP D ASS'Y ORANGE	1	
076	603-04201-20	TANK HOLDING BAND	1	
077	652-04201-20	CUSHION RUBBER	1	
078	994-15050-162	SCREW 5X16/PS	2	
096	626-32550-20	TANK CAP CHAIN	1	

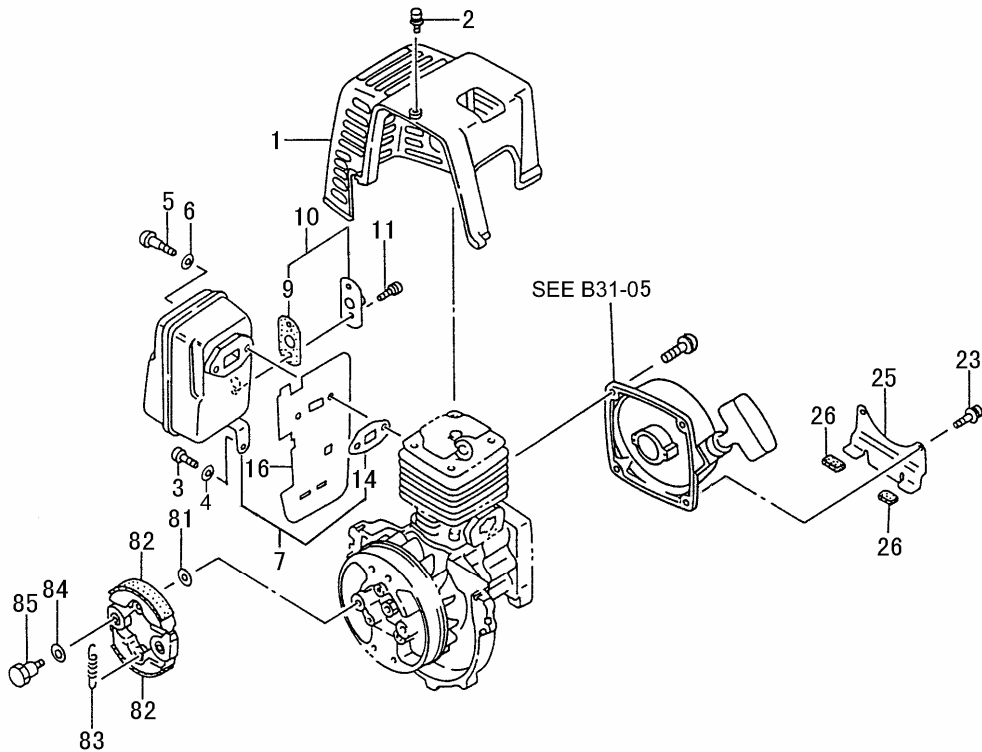
**B31-04 CG47EY(T) ENGINE-2**

REF. NUMBER	PARTS NUMBER	DESCRIPTION	Q'TY	SERIAL NUMBER
001	738-04220-20	MUFFLER PROTECTOR	1	
002	994-15050-122	SCREW 5X12/PS	1	
003	994-61050-124	HEX. HOLE BOLT 5X12S	1	
004	992-01050-061	WASHER 5	1	
005	990-53060-653	HEX. HOLE BUTTON SCREW	2	
006	992-01060-011	WASHER 6	2	
007	704-0422S-90	MUFFLER SET	1	
009	751-04200-20	MUFFLER SPECIAL GASKET	1	
010	721-0423Z-90	TAIL PIPE SET, SPARE	1	
011	994-14040-081	SCREW 4X8/S	2	
014	737-04230-20	MUFFLER GASKET	1	
016	133-04230-20	HEAT SHIELD	1	
023	994-15050-182	SCREW 5X18/PS	2	
025	653-04200-20	TANK BRACKET	1	
026	655-06100-20	FUEL TANK CUSHION RUBB	2	
081	359-10112-20	CLUTCH WASHER B	2	
082	290-04270-80	CLUTCH ARM	2	
083	342-04270-20	CLUTCH SPRING	1	
084	992-04100-030	WAVE WASHER 10	2	
085	357-0136U-20	CLUTCH STEP BOLT	2	

**B31-05 CG47EY(T) RECOIL STARTER**

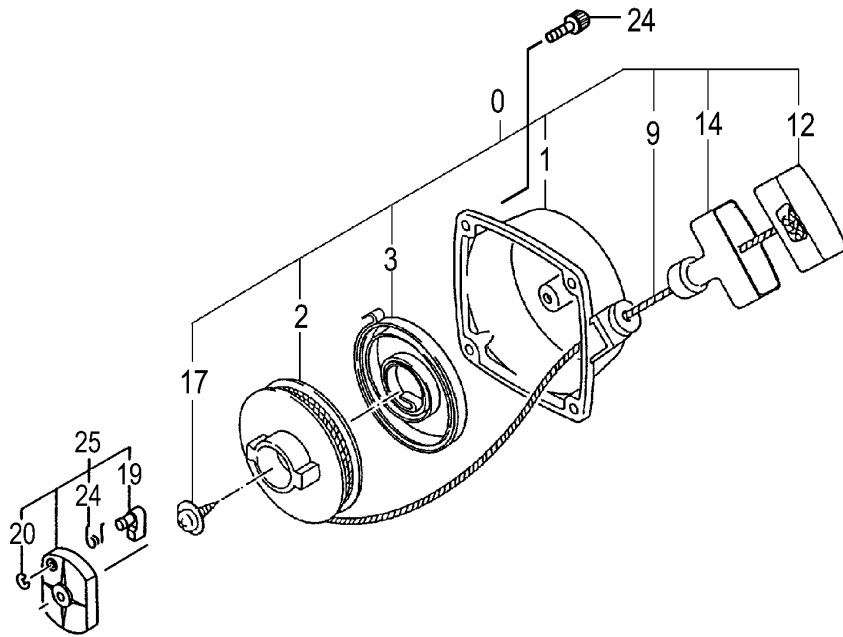

REF. NUMBER	PARTS NUMBER	DESCRIPTION	Q'TY	SERIAL NUMBER
000	762-04220-90	RECOIL STARTER BODY AS	1	
001	772-04220-80	RECOIL STARTER BODY CO	1	
002	769-04220-20	STARTER ROPE REEL	1	
003	779-04220-20	RECOIL SPRING	1	
009	783-04270-20	STARTER ROPE	1	
012	835-04220-20	STARTER HANDLE CAP	1	
014	785-04220-20	STARTER HANDLE	1	
017	839-04220-20	SET SCREW	1	
019	788-0162V-20	STARTER PAWL	1	
020	993-55050-000	STOP RING E-5	1	
024	790-0162V-20	STARTER PAWL SPRING	1	
025	798-04220-90	STARTER PULLEY	1	
024	994-15050-252	SCREW 5X25PS	2	

**B31-06 CG47EY(T) AIR CLEANER**

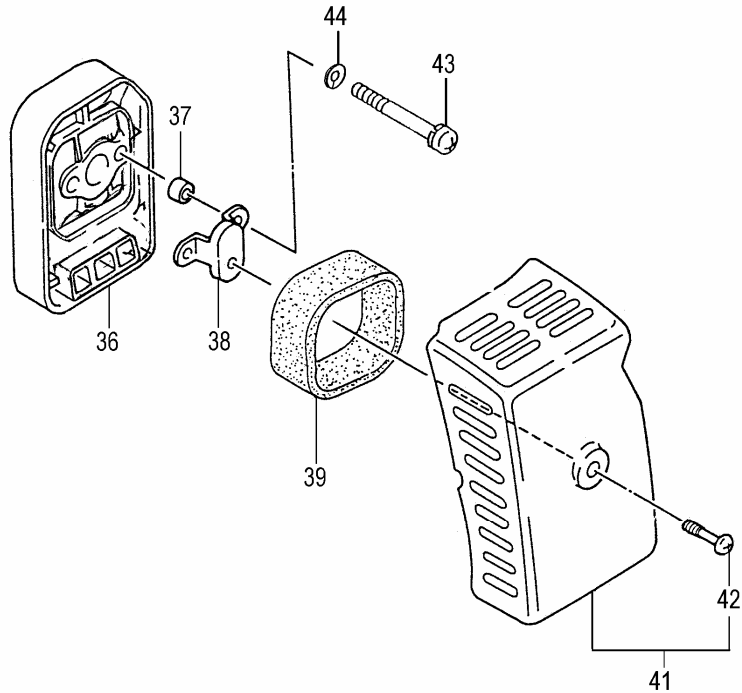

REF. NUMBER	PARTS NUMBER	DESCRIPTION	Q'TY	SERIAL NUMBER
036	423-04270-20	CLEANER BODY	1	
037	659-00801-20	COLLAR 5.8	2	
038	476-0422U-80	BLOW OVER CHECK BOARD	1	
039	446-04270-20	CLEANER ELEMENT	1	
041	424-04270-90	CLEANER COVER ASS'Y	1	
042	450-04072-20	COVER FIXING BOLT	1	
043	990-11050-601	SCREW 5X60	2	
044	992-10050-012	S.WASHER 5	2	

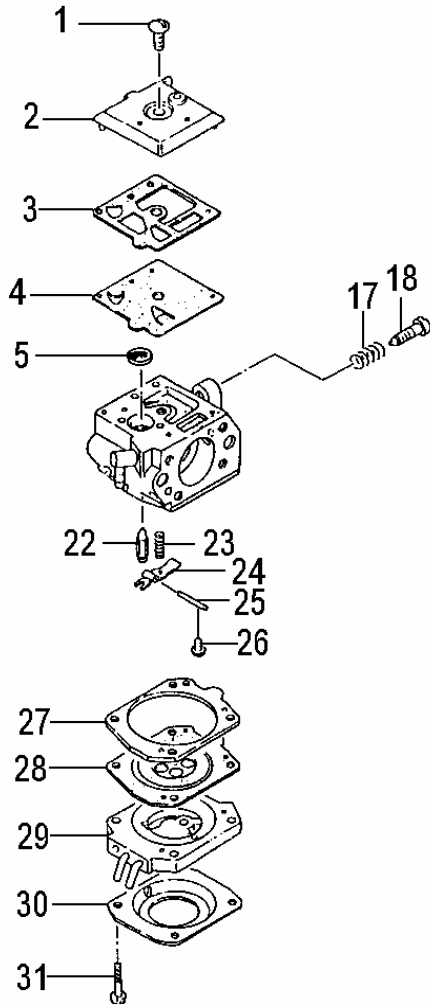
**B31-07****CG47EY(T) CABURETOR**

REF. NUMBER	PARTS NUMBER	DESCRIPTION	Q'TY	SERIAL NUMBER
001	514-25001-20	SET SCREW	1	
002	575-25012-20	PUMP BODY	1	
003	577-25012-20	PUMP GASKET	1	
004	576-25012-20	PUMP DIAPHRAGM	1	
005	578-25007-20	INLET SCREEN	1	
017	463-25012-20	IDLE ADJUST SPRING	1	
018	462-25006-20	IDLE ADJUST SCREW	1	
022	603-25012-20	NEEDLE VALVE	# 1	
023	477-25307-20	VALVE SPRING	1	
024	473-25012-20	CONTROL LEVER	1	
025	605-25001-20	HINGE PIN	1	
026	546-25001-20	HINGE PIN SET SCREW	1	
027	475-25032-20	DIAPHRAGM GASKET	1	
028	474-25032-80	METERING DIAPHRAGM CO	1	
029	454-25032-80	AIR PURGE COMP.	1	
030	476-25032-20	DIAPHRAGM COVER	1	
031	548-25016-20	SET SCREW	4	

**B31-08 CG47EY(T) FAN CASE**

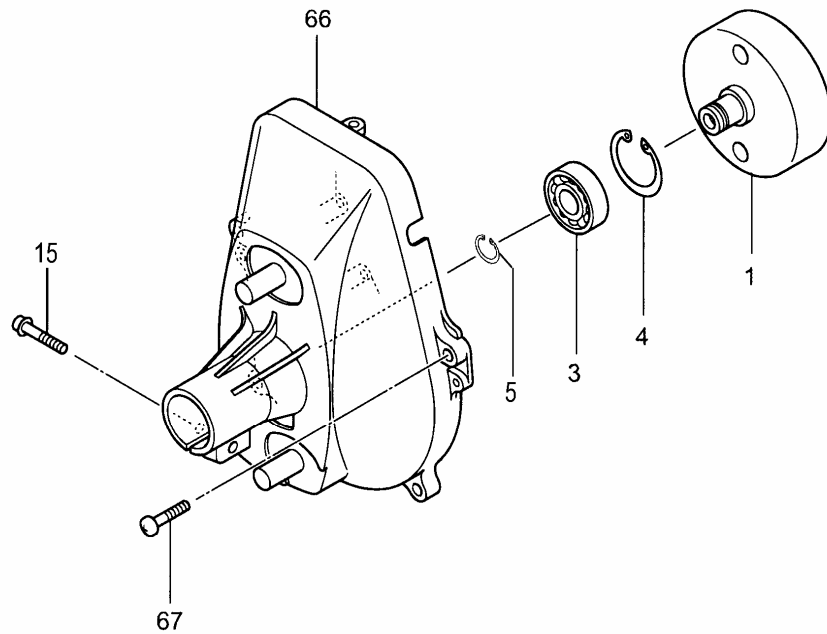

REF. NUMBER	PARTS NUMBER	DESCRIPTION	Q'TY	SERIAL NUMBER
001	289-04308-80	CLUTCH SHAFT COMP.	1	
003	999-61620-201	BALL BEARING #6202ZZ, 35M	1	
004	993-51035-002	STOP RING C-35, INNER	1	
005	993-50015-002	STOP RING C-15, OUTER	1	
015	990-54060-253	HEX.HOLE BOLT 6X25	1	
066	112-04280-22	FAN CASE OR	1	
067	994-14060-202	SCREW 6X20/S	4	



**B31-10 CG47EY(T) THROTTLE LAVER**

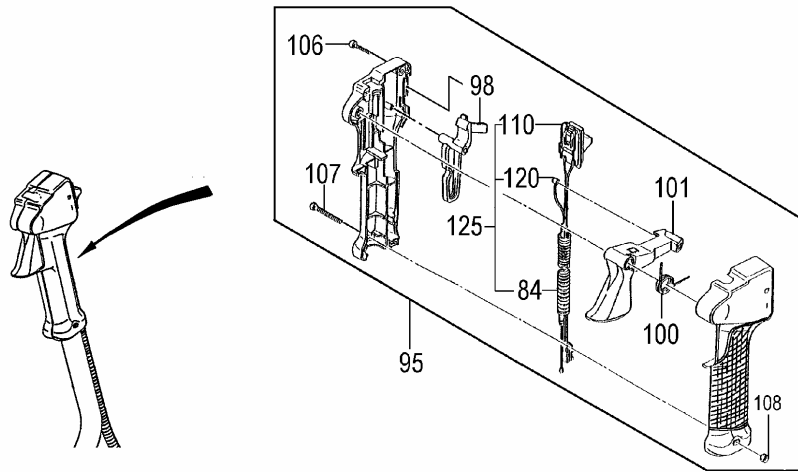

REF. NUMBER	PARTS NUMBER	DESCRIPTION	Q'TY	SERIAL NUMBER
084	164-07099-00	PROTECTION TUBU 990L	1	
095	870-37180-91	THROTTLE LEVER 20	1	
098	253-38400-20	SAFETY LEVER	1	
100	832-38400-20	RETURN SPRING	1	
101	880-38401-20	THROTTLE LEVER	1	
106	993-46040-202	SCREW 4X20, BLACK	2	
107	994-31050-303	SCREW 5X30, BLACK	1	
108	991-01050-043	CONTAL NUT 5	1	
110	156-37180-80	STOP BOTTOM COMP.	1	
120	887-37180-80	THROTTLE WIRE	1	
125	885-37180-81	THROTTLE WIRE COMP.	1	

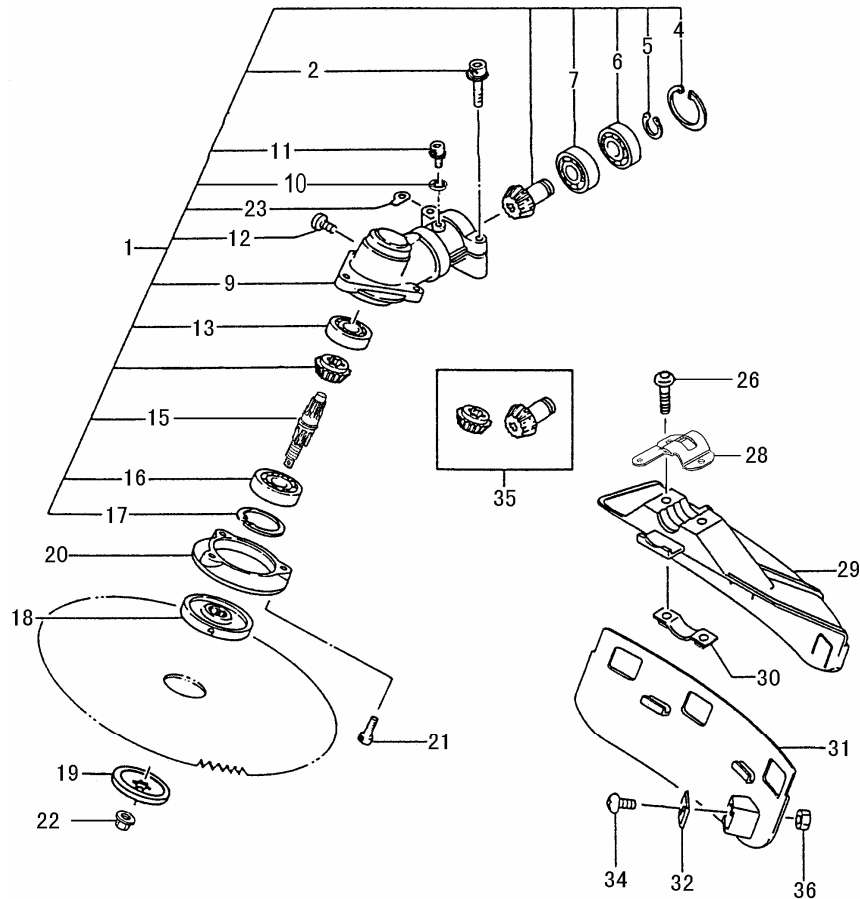
**B31-11 CG47EY(T) GEAR CASE**

REF. NUMBER	PARTS NUMBER	DESCRIPTION	Q'TY	SERIAL NUMBER
001	300-37861-91	GEAR CASE ASS'Y, 30 DIA	1	
002	994-61050-254	HEX. HOLE BOLT 5X25/S	2	
004	993-51028-002	STOP RING C-28, INNER	1	
005	993-50012-002	STOP RING C-12, OUTER	1	
006	999-61600-102	BALL BEARING #6001Z, 28MM	1	
007	999-61600-115	BALL BEARING 6001 C3	1	
009	300-33392-21	GEARCASE, SILVER	1	
010	992-10050-062	S.WASHER 5	1	
011	990-51050-123	HEX. HOLE BOLT 5X12	1	
012	994-23080-100	PLUS HEAD BOLT 8X10	1	
013	999-61600-000	BALL BEARING #6000, 26MM	1	
015	304-37850-21	GEAR SHAFT 6X11X14	1	
016	999-61620-303	BALL BEARING #6203D, 40MM	1	
017	993-51040-002	STOP RING C-40, INNER	1	
018	310-37100-22	CUTTER HOLDER	1	
019	311-37861-20	CUTTER HOLDER CAP,6X11	1	
020	307-37100-81	PROTECTION COVER A COM	1	
021	994-16050-162	SCREW 5X16/WS	3	
022	313-38100-20	CUTTER FIXING NUT,L/H	1	
023	324-37110-20	GEAR CASE WASHER	2	
026	994-81060-254	HEX. HOLE BUTTON SCREW	2	
028	442-37121-20	COVER BRACKET, 30 DIA.	1	
029	441-37130-21	BLADE GUARD 30 CE	1	
030	445-37380-20	SAFETY COVER HOLDER	1	
031	447-37380-20	COVER GUARD	1	
032	797-37380-21	KNIFE	1	
034	994-14050-121	SCREW 5X12/S	1	
035	301-37100-00	GEAR-PINION SET, SPARE	1	
036	991-01050-011	HEX. NUT 5	1	

**B31-12 CG47EY(T) TOOLS**

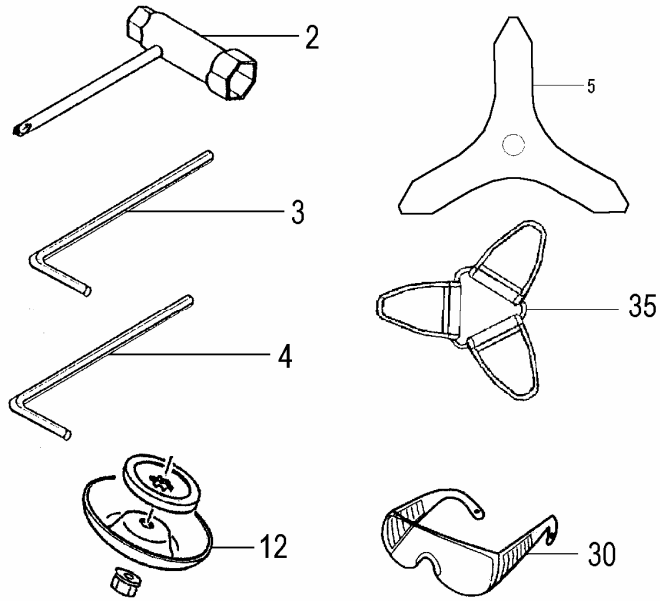

REF. NUMBER	PARTS NUMBER	DESCRIPTION	Q'TY	SERIAL NUMBER
002	826-20000-80	COMBI, BOX WRENCH 17X19	1	
003	814-20000-20	HEX. WRENCH 5	1	
004	813-20000-20	HEX. WRENCH 4	1	
005	810-37181-20	CUTTING BLADE 3TX305XT3	1	
012	308-37861-20	PROTECTION COVER B	1	
030	541-37590-20	PROTECTION GLASSES	1	
035	615-37181-20	CUTTER COVER	1	
#REF!	#REF!	#REF!	####	

