

Vue éclatée modèle CS 25EC S

Serial n° xx

ITEM N°	CODE N°	DESCRIPTION	N° Used	x	x	x	x	x	x	x
		MODEL : CS25ECS								0
		C24-01 CYLINDER/PISTON/CRANK								0
001	157-01570-90	SPARK PLUG CAP ASS'Y	1							0 *07
002	018-00546-21	SPARK PLUG BMR6A	1							0 82004
006	001-01762-90	CYLINDER SET	1							0 82005
009	017-01761-20	CYLINDER GASKET	1							0 82006
010	041-01000-20	PISTON RING	1							0
011	030-01760-90	PISTON SET	1							0
012	037-07045-20	PISTON PIN	1							0
013	039-00601-20	PISTON PIN CIRCLIP	2							0
016	046-01761-80	CRANK SHAFT COMP.	1							0
031	994-63040-154	HEX.HOLE BOLT 4X15/PS	2							0
032	167-20557-80	IGNITION COIL COMP.	1							0
035	755-32050-20	CORD INSULATOR TUBE	1							0
		C24-02 CRANK CASE								0
019	071-04063-23	SHIM 0.2	V							0
019	071-04063-24	SHIM 0.3	V							0
019	071-04063-25	SHIM 0.4	V							0
021	066-00000-20	FLYWHEEL NUT 12	1							0
023	992-01070-011	WASHER 7	1							0
024	155-20557-90	MAGNETO ROTOR SET	1							0
026	788-01761-20	STARTER PAWL	2							0
027	790-01740-20	STARTER PAWL SPRING	2							0
028	993-55040-001	STOP RING	2							0
030	700-52545-17	FUEL PIPE 2.5X4.5X175	1							0
031	680-00102-20	CLIP 4.5	1							0
035	250-06500-20	INSULATOR TUBE, 50L	1							0
036	990-51050-163	HEX. HOLE BOLT 5X16	4							0
037	992-00050-061	SMALL WASHER 5	4							0
041	072-01761-91	CRANK CASE ASS'Y	1							0
042	999-66122-200	OIL SEAL TB 12227	2							0
043	090-01761-20	CRANK CASE GASKET	1							0
044	999-61600-115	BALL BEARING 6001 C3	2							0
046	999-05250-980	NEEDLE ROLLER 2.5X9.8	2							0
050	994-64050-224	HEX.HOLE BOLT 5X22/WS	4							0
		C24-03 INLETMANIFOLD/CARBURET								0
040	145-01761-90	AIR DEFLECTOR ASS'Y	1							0
042	581-72000-20	PIPE HOLDING GROMMET	1							0
045	403-01761-20	INLETMANIFOLD GASKET	1							0
049	400-72000-20	INLETMANIFOLD SPACER	1							0
050	391-01761-80	INLETMANIFOLD COMP.	1							0
058	406-01761-20	CARB. FIXING PLATE	1							0
060	470-72001-20	DUST COVER	1							0
061	707-32550-20	CHOKE RUBBER	1							0
062	704-72000-80	CHOKE BUTTOM COMP.	1							0
063	457-72000-20	CARB. SUPPORT PLATE	1							0
064	190-72011-21	ADJUSTER CAP	1							0
065	191-72000-20	IDLE GROMMET	1							0
066	991-74050-010	U-NUT 5	2							0
070	994-61040-104	HEX. HOLE BOLT 4X10S	2							0

ITEM N°	CODE N°	DESCRIPTION	N° Used	x	x	x	x	x	x	x
		MODEL : CS25ECS								0
015	475-25038-20	DIAPHRAGM GASKET	1							0
016	603-25012-20	NEEDLE VALVE #	1							0
021	463-25012-20	IDLE ADJUST SPRING	1							0
022	462-25006-20	IDLE ADJUST SCREW	1							0
025	548-25012-20	SET SCREW	4							0
		C24-07 OIL PUMP/MUFFLER								0
010	990-75045-144	TAPPING SCREW 4.5X14	3							0
011	097-72000-20	OIL PUMP COVER	1							0
012	515-72000-20	OIL PIPE A	1							0
013	084-72000-20	GEAR SHAFT	1							0
014	567-01761-20	AIR VENT SPONGE	1							0
015	088-72000-90	OIL PUMP CASE ASS'Y	1							0
016	085-72000-80	PUMP GEAR COMP.	1							0
017	099-72000-20	PUMP GEAR SPRING	1							0
018	503-72000-20	OIL PUMP ADJUSTER CAP	1							0
019	088-72000-80	OIL PUMP CASE COMP.	1							0
020	502-72000-20	ADJUSTER SPRING	1							0
021	992-01040-011	WASHER 4	1							0
025	501-72000-20	OIL PUMP ADJUSTER	1							0
026	990-11030-081	SCREW 3X8	1							0
028	704-01761-90	MUFFLER SET	1							0
031	994-14040-141	SCREW 4X14/S	2							0
030	488-72000-20	OIL ADJUST GROMMET	1							0
033	737-01700-20	MUFFLER GASKET	1							0
036	990-51050-403	HEX. HOLE BOLT 5X40	2							0
037	992-01050-011	WASHER 5	2							0
038	700-07105-02	VINYL PIPE 7X10.5X20	1							0
039	125-32710-20	CHAIN CATCHER	1							0
040	737-72010-20	MUFFLER COVER	1							0
042	990-75045-144	TAPPING SCREW 4.5X14	2							0
043	990-72050-144	TAPPING SCREW 5X14	1							0
045	461-72000-20	GUIDE PLATE A	1							0
046	993-41040-101	SCREW 4X10	1							0
		C24-08 CLUTCH/CHAIN BRAKE								0
002	121-32530-20	CHAIN BAR CLAMP NUT	1							0
004	287-01761-90	CLUTCH COMP.	1							0
005	999-62101-301	NEEDLE BRG 101310 1.5X7.5	1							0
006	310-72001-80	CLUTCH HOUSING COMP.	1							0
007	358-01761-20	CLUTCH WASHER	1							0
008	359-01761-20	CLUTCH WASHER	1							0
021	345-01761-20	CLUTCH SHOE	3							0
023	342-01761-20	CLUTCH SPRING	3							0
031	993-41040-101	SCREW 4X10	2							0
032	462-72000-20	GUIDE PLATE B	1							0
033	116-72000-80	TENTION ADJUST BOLT COMP.	1							0
034	301-72000-20	GEAR A	1							0
035	808-72000-20	HAND GUARD WEIGHT	1							0
037	511-72000-20	CRANK SHAFT COLLAR 6	1							0
038	991-01040-011	HEX. NUT 4	1							0
041	994-14040-121	SCREW 4X12/S	1							0
046	040-72000-90	SIDE CASE ASS'Y	1							0
049	365-72000-20	BRAKE HANDLE	1							0
052	375-72000-20	BRAKE LINK COVER	1							0
054	374-72000-20	BRAKE SPRING	1							0

C24-01 CS25EC(S) CYLINDER/PISTON/CRANK SHAFT

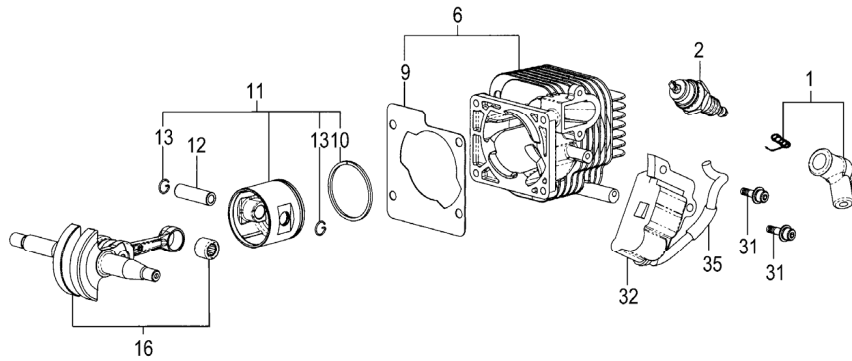

REF. NUMBER	PARTS NUMBER	DESCRIPTION	Q'TY	SERIAL NUMBER
001	157-01570-90	SPARK PLUG CAP ASS'Y	1	
002	018-00546-21	SPARK PLUG BMR6A	1	
006	001-01762-90	CYLINDER SET	1	
009	017-01761-20	CYLINDER GASKET	1	
010	041-01000-20	PISTON RING	1	
011	030-01760-90	PISTON SET	1	
012	037-07045-20	PISTON PIN	1	
013	039-00601-20	PISTON PIN CIRCLIP	2	
016	046-01761-80	CRANK SHAFT COMP.	1	
031	994-63040-154	HEX.HOLE BOLT 4X15/PS	2	
032	167-20557-80	IGNITION COIL COMP.	1	
035	755-32050-20	CORD INSULATOR TUBE	1	

C24-02 CS25EC(S) CRANK CASE

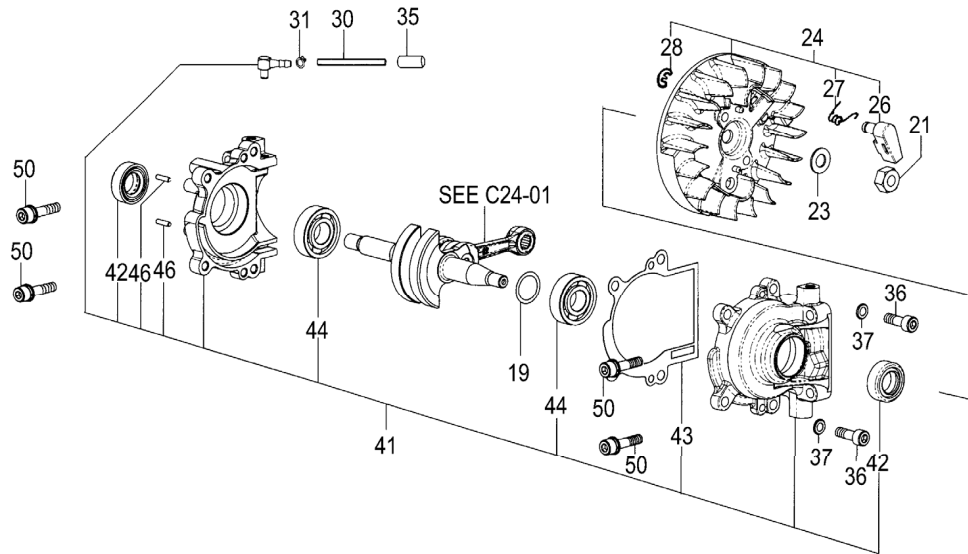

REF. NUMBER	PARTS NUMBER	DESCRIPTION	Q'TY	SERIAL NUMBER
019	071-04063-23	SHIM 0.2	V	
019	071-04063-24	SHIM 0.3	V	
019	071-04063-25	SHIM 0.4	V	
021	066-00000-20	FLYWHEEL NUT 12	1	
023	992-01070-011	WASHER 7	1	
024	155-20557-90	MAGNETO ROTOR SET	1	
026	788-01761-20	STARTER PAWL	2	
027	790-01740-20	STARTER PAWL SPRING	2	
028	993-55040-001	STOP RING	2	
030	700-52545-17	FUEL PIPE 2.5X4.5X175	1	
031	680-00102-20	CLIP 4.5	1	
035	250-06500-20	INSULATOR TUBE, 50L	1	
036	990-51050-163	HEX. HOLE BOLT 5X16	4	
037	992-00050-061	SMALL WASHER 5	4	
041	072-01761-91	CRANK CASE ASS'Y	1	
042	999-66122-200	OIL SEAL TB 12227	2	
043	090-01761-20	CRANK CASE GASKET	1	
044	999-61600-115	BALL BEARING 6001 C3	2	
046	999-05250-980	NEEDLE ROLLER 2.5X9.8	2	
050	994-64050-224	HEX.HOLE BOLT 5X22/WS	4	

C24-03 CS25EC(S) ENGINE CASE/AIR CLEANER

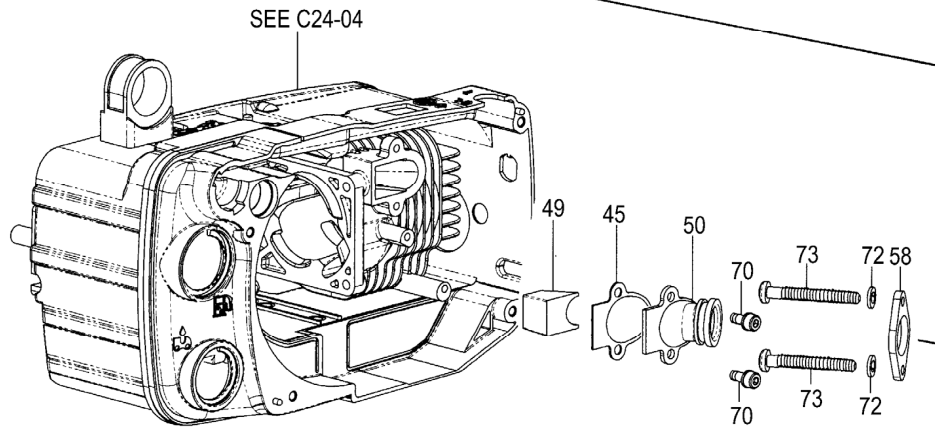
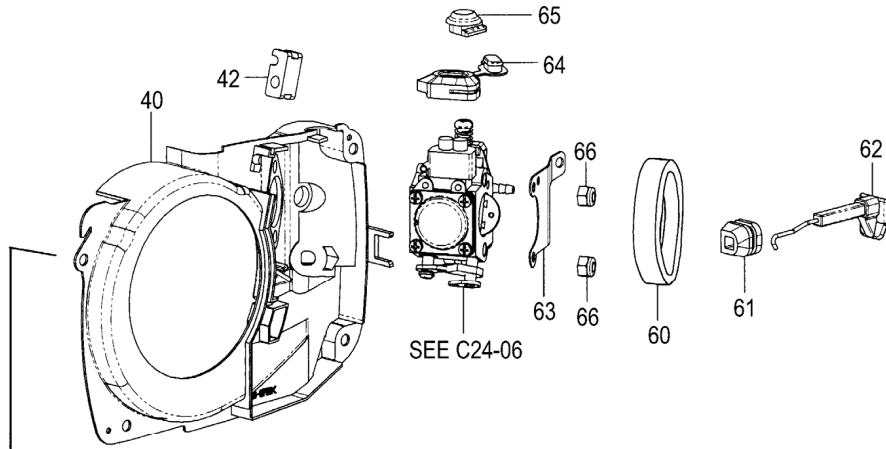

REF. NUMBER	PARTS NUMBER	DESCRIPTION	Q'TY	SERIAL NUMBER
040	145-01761-90	AIR DEFLECTOR ASS'Y	1	
042	581-72000-20	PIPE HOLDING GROMMET	1	
045	403-01761-20	INLETMANIFOLD GASKET	1	
049	400-72000-20	INLETMANIFOLD SPACER	1	
050	391-01761-80	INLETMANIFOLD COMP.	1	
058	406-01761-20	CARB. FIXING PLATE	1	
060	470-72001-20	DUST COVER	1	
061	707-32550-20	CHOKE RUBBER	1	
062	704-72000-80	CHOKE BUTTOM COMP.	1	
063	457-72000-20	CARB. SUPPORT PLATE	1	
064	190-72011-21	ADJUSTER CAP	1	
065	191-72000-20	IDLE GROMMET	1	
066	991-74050-010	U-NUT 5	2	
070	994-61040-104	HEX. HOLE BOLT 4X10S	2	
072	992-01050-011	WASHER 5	2	
073	990-11050-451	SCREW 5X45	2	

C24-04 CS25EC(S) FUEL LINE/OIL FILTER

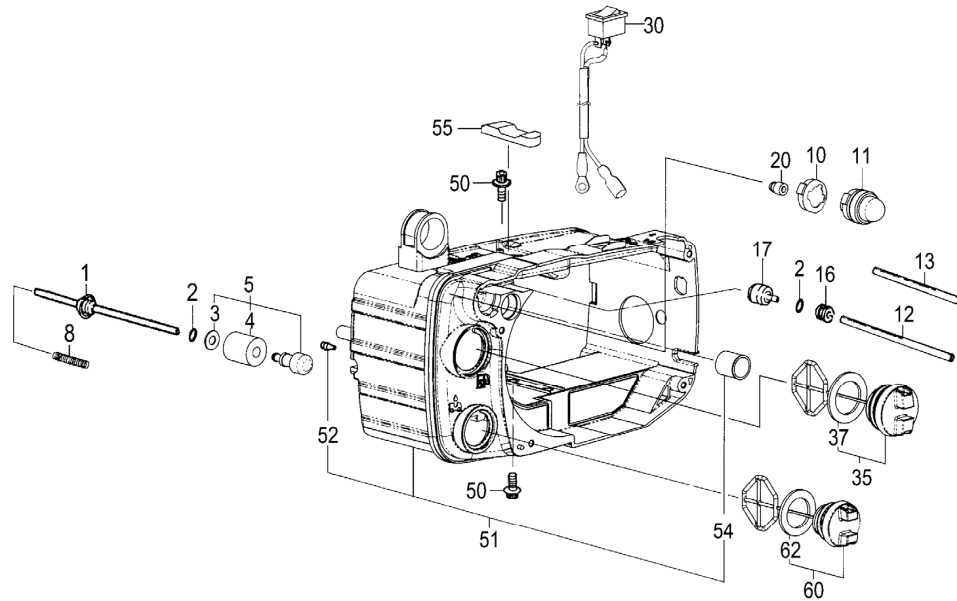

REF. NUMBER	PARTS NUMBER	DESCRIPTION	Q'TY	SERIAL NUMBER
001	223-06500-90	FUEL PIPE ASS'Y L=130	1	
002	680-00070-20	CLIP	2	
003	992-01050-011	WASHER 5	1	
004	487-32712-20	OIL FILTER	1	
005	486-32710-90	OIL FILTER BODY ASS'Y	1	
008	512-11600-20	PROTECTION COIL	1	
010	638-72000-20	PUMP FIXING PLATE	1	
011	442-25143-80	PRIMING PUMP COMP.	1	
012	700-52545-26	FUEL PIPE	1	
013	700-02504-14	FUIL PIPE 2.5X4.5X140	1	
016	701-72000-20	FUEL GROMMET	1	
017	675-11600-90	PUMP FILTER BODY ASS'Y	1	
020	534-72000-20	RETURN GROMMET	1	
030	162-01761-80	STOP SWITCH COMP.	1	
035	635-72001-90	TANK CAP ASS'Y	1	
037	630-3252K-20	TANK CAP GASKET	1	
050	990-54050-155	FLANGE HEX HOLE BOLT 5X15	4	
051	560-72010-90	ENGINE CASE ASS'Y	1	
052	562-04060-20	AIR VENT VALVE B	1	
054	629-01761-90	AIR VENT ASS'Y	1	
055	563-72000-20	ENGINE CASE COVER	1	
060	642-3252K-90	OIL TANK CAP ASS'Y	1	
062	523-3252K-20	OIL TANK CAP GASKET	1	

C24-05 CS25EC(S) RECOIL STARTER

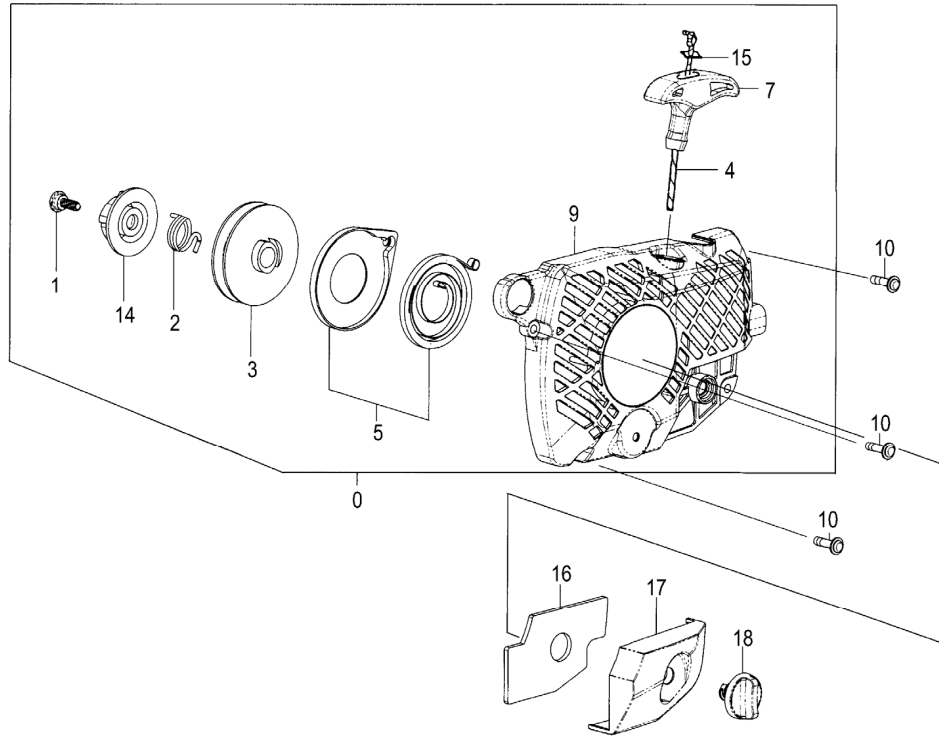

REF. NUMBER	PARTS NUMBER	DESCRIPTION	Q'TY	SERIAL NUMBER
000	756-01761-90	RECOIL STARTER ASS'Y	1	
001	839-03045-20	SET SCREW	1	
002	758-01761-20	DUMPER SPRING	1	
003	774-01761-20	STARTER PULLY	1	
004	783-01761-20	ROPE	1	
005	778-01761-90	RECOIL SPRING CASE ASS'Y	1	
007	785-01761-20	STARTER HANDLE	1	
009	112-01761-80	FAN CASE COMP.	1	
010	990-72045-204	TAPPING SCREW 4.5X20	4	
014	759-01761-20	CAM PLATE	1	
015	795-04063-20	ROPE STOPPER	1	
016	420-01761-20	CLEANER ELEMENT	1	
017	051-72000-20	CLEANER COVER	1	
018	175-72000-20	CLEANER KNOB	1	

C24-06 CS25EC(S) CARBURETOR

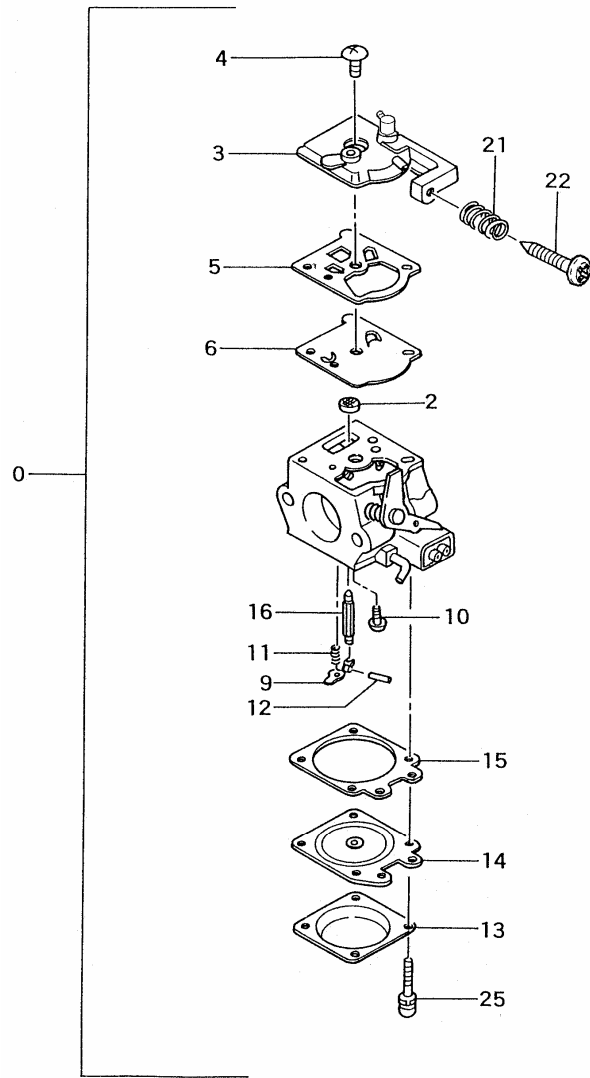

REF. NUMBER	PARTS NUMBER	DESCRIPTION	Q'TY	SERIAL NUMBER
000	455-25329-90	CARBURETOR ASS'Y WT-797A	1	
002	578-25007-20	INLET SCREEN	1	
003	575-25329-80	PUMP COVER	1	
004	514-25001-20	SET SCREW	1	
005	577-25007-20	PUMP GASKET	1	
006	576-25006-20	PUMP DIAPHRAGM	1	
009	473-25001-20	VALVE HINGE	1	
010	546-25001-20	HINGE PIN SET SCREW	1	
011	477-25088-20	VALVE SPRING	1	
012	605-25001-20	HINGE PIN	1	
013	476-25004-20	DIAPHRAGM COVER	1	
014	474-25001-80	METERING DIAPHRAGM COMP	1	
015	475-25038-20	DIAPHRAGM GASKET	1	
016	603-25012-20	NEEDLE VALVE #	1	
021	463-25012-20	IDLE ADJUST SPRING	1	
022	462-25006-20	IDLE ADJUST SCREW	1	
025	548-25012-20	SET SCREW	4	

C24-07 CS25EC(S) OIL PUMP/MUFFLER

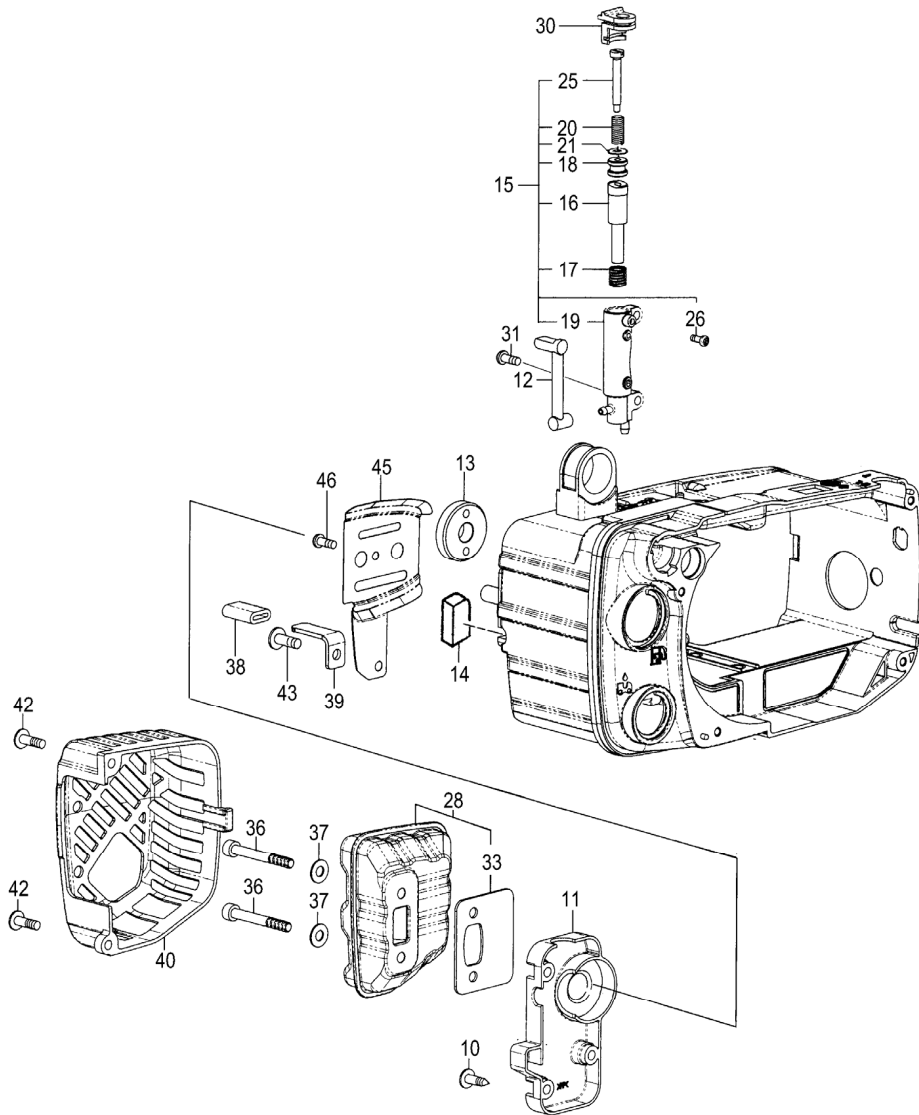

REF. NUMBER	PARTS NUMBER	DESCRIPTION	Q'TY	SERIAL NUMBER
010	990-75045-144	TAPPING SCREW 4.5X14	3	
011	097-72000-20	OIL PUMP COVER	1	
012	515-72000-20	OIL PIPE A	1	
013	084-72000-20	GEAR SHAFT	1	
014	567-01761-20	AIR VENT SPONGE	1	
015	088-72000-90	OIL PUMP CASE ASS'Y	1	
016	085-72000-80	PUMP GEAR COMP.	1	
017	099-72000-20	PUMP GEAR SPRING	1	
018	503-72000-20	OIL PUMP ADJUSTER CAP	1	
019	088-72000-80	OIL PUMP CASE COMP.	1	
020	502-72000-20	ADJUSTER SPRING	1	
021	992-01040-011	WASHER 4	1	
025	501-72000-20	OIL PUMP ADJUSTER	1	
026	990-11030-081	SCREW 3X8	1	
028	704-01761-90	MUFFLER SET	1	
031	994-14040-141	SCREW 4X14/S	2	
030	488-72000-20	OIL ADJUST GROMMET	1	
033	737-01700-20	MUFFLER GASKET	1	
036	990-51050-403	HEX. HOLE BOLT 5X40	2	
037	992-01050-011	WASHER 5	2	
038	700-07105-02	VINYL PIPE 7X10.5X20	1	
039	125-32710-20	CHAIN CATCHER	1	
040	737-72010-20	MUFFLER COVER	1	
042	990-75045-144	TAPPING SCREW 4.5X14	2	
043	990-72050-144	TAPPING SCREW 5X14	1	
045	461-72000-20	GUIDE PLATE A	1	
046	993-41040-101	SCREW 4X10	1	

C24-08 CS25EC(S) CLUTCH/CHAIN BRAKE

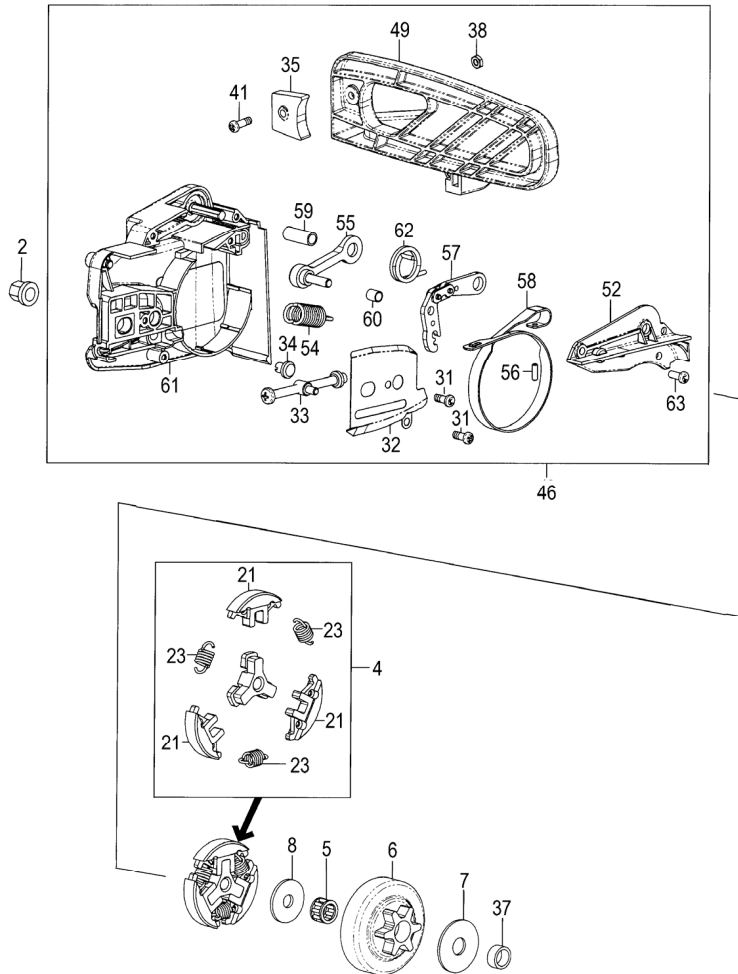

REF. NUMBER	PARTS NUMBER	DESCRIPTION	Q'TY	SERIAL NUMBER
002	121-32530-20	CHAIN BAR CLAMP NUT	1	
004	287-01761-90	CLUTCH COMP.	1	
005	999-62101-301	NEEDLE BRG 101310 1.5X7.5	1	
006	310-72001-80	CLUTCH HOUSING COMP.	1	
007	358-01761-20	CLUTCH WASHER	1	
008	359-01761-20	CLUTCH WASHER	1	
021	345-01761-20	CLUTCH SHOE	3	
023	342-01761-20	CLUTCH SPRING	3	
031	993-41040-101	SCREW 4X10	2	
032	462-72000-20	GUIDE PLATE B	1	
033	116-72000-80	TENTION ADJUST BOLT COMP	1	
034	301-72000-20	GEAR A	1	
035	808-72000-20	HAND GUARD WEIGHT	1	
037	511-72000-20	CRANK SHAFT COLLAR 6	1	
038	991-01040-011	HEX. NUT 4	1	
041	994-14040-121	SCREW 4X12/S	1	
046	040-72000-90	SIDE CASE ASS'Y	1	
049	365-72000-20	BRAKE HANDLE	1	
052	375-72000-20	BRAKE LINK COVER	1	
054	374-72000-20	BRAKE SPRING	1	
055	386-32901-80	BRAKE LINK SUPPORT COMP.	1	
056	999-05300-980	NEEDLE ROLLER 3X9.8	1	
057	379-32901-80	BRAKE LINK COMP.	1	
058	378-72000-20	BLAKE BAND	1	
059	470-10246-20	CLEANER FIXING COLLAR	1	
060	031-32901-20	COLLAR 7	1	
061	039-72000-80	SIDE COVER COMP.	1	
062	388-32900-20	BLAKE LEVER SPRING	1	
063	993-41040-151	HI-LO SCREW 4X15	3	

C24-09 CS25EC(S) HANDLE

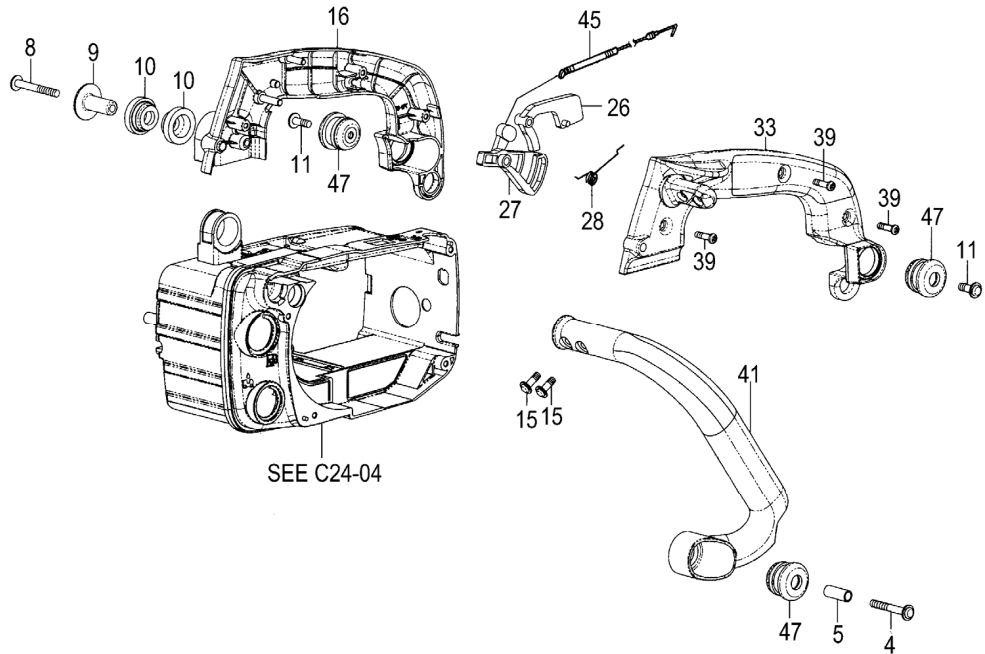

REF. NUMBER	PARTS NUMBER	DESCRIPTION	Q'TY	SERIAL NUMBER
004	990-73050-354	TAPPING SCREW 5X35	1	
005	470-10246-20	CLEANER FIXING COLLAR	1	
008	990-73050-404	TAPPING SCREW 5X40	1	
009	275-32710-20	DAMPER COLLAR A	1	
010	219-32750-20	DAMPER A	2	
011	990-72050-144	TAPPING SCREW 5X14	2	
015	990-73050-164	TAPPING SCREW 5X16	2	
016	011-72000-20	REAR HANDLE B	1	
026	257-32910-20	SAFETY LEVER	1	
027	060-32970-20	THROTTLE LEVER	1	
028	061-32710-20	THROTTLE LEVER SPRING	1	
033	010-72000-20	REAR HANDLE A	1	
039	993-41040-151	HI-LO SCREW 4X15	3	
041	209-72000-21	FRONT HANDLE	1	
045	885-01761-80	THROTTLE WIRE COMP.	1	
047	244-3291D-80	DAMPER COMP.	3	

C24-10 CS25EC(S) COVER/CHAIN/CHAIN BAR

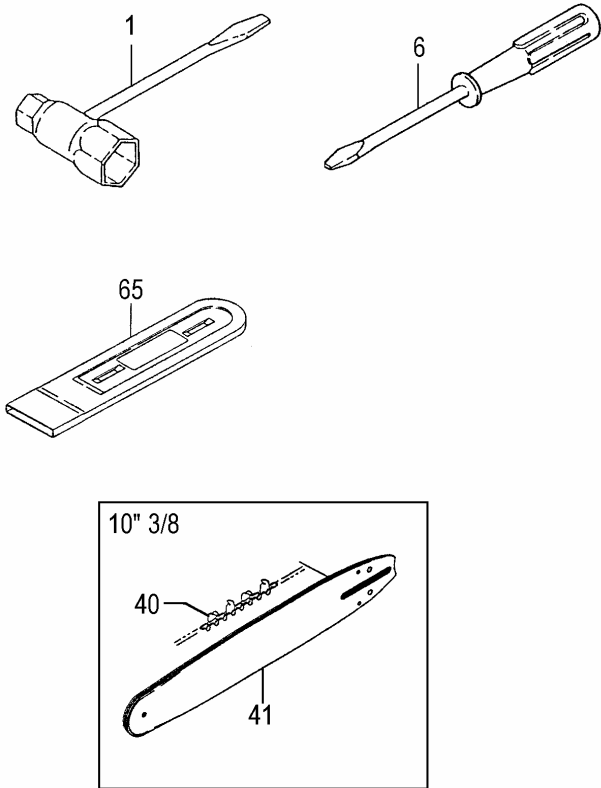

REF. NUMBER	PARTS NUMBER	DESCRIPTION	Q'TY	SERIAL NUMBER
001	013-29720-00	COMBI BOX SPANA 10X19	1	
006	081-29720-00	DRIVER	1	
040	127-72000-20	CHAIN 10 3/8	1	
041	110-72004-20	CHAIN BAR 10 3/8	1	
065	941-32333-20	CHAIN COVER 10	1	

C24-11 CS25EC(S) LABELS

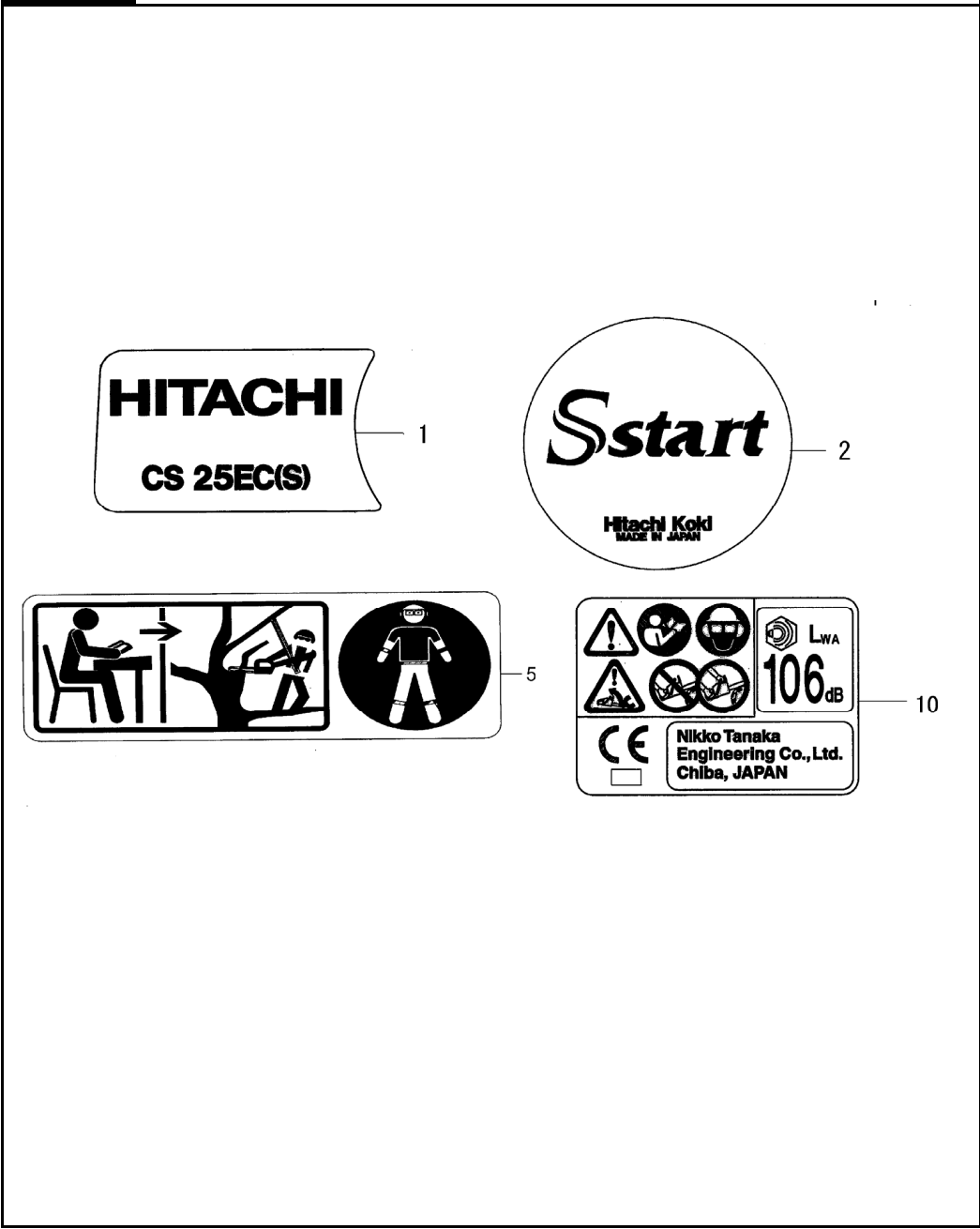

REF. NUMBER	PARTS NUMBER	DESCRIPTION	Q'TY	SERIAL NUMBER
001	906-72004-20	NAME PLATE CS25EC(S)	1	
010	909-72001-22	CAUTION MARK A	1	
011	919-72001-20	CAUTION MARK A	1	