

## Vue éclatée modèle CS 30EG(S) - tronçonneuse

Serial n° xx

ITEM N°	CODE N°	DESCRIPTION	N° Used	x	x	x	x	x	x
		<b>MODEL : CS 30EG(S)</b>							0
		C17-01 CYLINDER/PISTON/CRANK							0
001	157-11666-90	SPARK PLUG CAP ASS'Y	1						0 *07
002	018-00562-20	SPARK PLUG RCJ-8	1						0 82900
006	001-01740-91	CYLINDER SET	1						0 82901
007	994-61050-164	HEX. HOLE BOLT 5X16S	4						0
009	017-01740-20	CYLINDER GASKET	1						0
010	041-01730-20	PISTON RING	2						0
011	030-01741-90	PISTON SET	1						0
012	037-01400-20	PISTON PIN	1						0
013	039-00000-20	PISTON PIN CIRCLIP	2						0
016	046-01740-80	CRANK SHAFT COMP.	1						0
017	999-62091-325	NEEDLE BRG F-910 1.4X8.5	1						0
018	068-10100-20	WOOD-RUFF KEY 3X13X4.5	1						0
031	994-16040-186	HIGH TENSION SCREW 4X18WS	2						0
034	205-01700-20	TAB	1						0
035	167-21540-80	IGNITION COIL COMP.	1						0
066	755-32050-20	CORD INSULATOR TUBE	1						0
075	178-01740-80	CORD, B 70M	1						0
		C17-02 CRANK CASE							0
019	071-04063-21	SHIM 0.1	V						0
019	071-04063-23	SHIM 0.2	V						0
019	071-04063-24	SHIM 0.3	V						0
019	071-04063-25	SHIM 0.4	V						0
021	066-00000-20	FLYWHEEL NUT 12	1						0
022	992-10070-012	S.WASHER 7	1						0
023	992-01070-011	WASHER 7	1						0
024	155-21540-90	MAGNETO ROTOR ASS'Y	1						0
026	788-01740-20	STARTER PAWL	2						0
027	790-01740-20	STARTER PAWL SPRING	2						0
028	993-55040-001	STOP RING	2						0
036	994-61050-204	HEX. HOLE BOLT 5X20/S	4						0
041	072-01740-94	CRANK CASE ASS'Y	1						0
042	999-66122-200	OIL SEAL TB 12227	2						0
043	090-0174G-20	CRANK CASE GASKET	1						0
044	999-61620-106	BALL BEARING 6201 A2C3,32MM/OD	2						0
046	999-05250-980	NEEDLE ROLLER 2.5X9.8	1						0
		C17-03 ENGINE CASE							0
051	560-32942-90	ENGINE CASE ASS'Y, VERMILION	1						0
052	562-04060-20	AIR VENT VALVE B	1						0
054	645-01750-90	AIR VENT VALVE SET	1						0
057	994-63050-204	HEX.HOLE BOLT 5X20PS	4						0
071	162-01570-90	STOP SWITCH ASS'Y	1						0
072	183-01300-20	SWITCH NAME PLATE	1						0
073	274-01700-80	EARTH CORD COMP.	1						0
		C17-04 AIR CLEANER							0
001	380-0631A-20	CLEANER COVER BOLT	1						0
002	051-3291J-91	CLEANER COVER	1						0
003	446-01740-20	AIRCLEANER SPONGE	1						0
004	420-01740-80	AIRCLEANER ELEMENT COMP.	1						0
005	994-14050-451	SCREW 5X45S	2						0
007	992-00050-011	SMALL WASHER 5	1						0

ITEM N°	CODE N°	DESCRIPTION	N° Used	x	x	x	x	x	x
		<b>MODEL : CS 30EG(S)</b>							0
008	708-32350-20	CHOKE SHIM 0.8	2						0
009	700-32918-20	CHOKE VALVE	1						0
010	455-32947-90	CARBURETOR SET,WT-760	1						0
011	402-01740-20	CARBURETOR GASKET	1						0
012	994-61050-204	HEX. HOLE BOLT 5X20/S	2						0
014	992-00050-011	SMALL WASHER 5	2						0
015	404-0174G-90	INSULATOR SET	1						0
016	394-0174G-20	REED VALVE	1						0
017	395-0174G-20	VALVE HOLDER	1						0
019	990-15030-121	BINDING HEAD SCREW 3X12	2						0
020	409-01700-20	CARBURETOR INSULATOR RUBBER	1						0
021	403-0174G-20	INSULATOR GASKET	1						0
036	990-75045-144	TAPPING SCREW 4.5X14	3						0
039	152-3290J-21	AIRCLEANER COVER B	1						0
045	129-01730-20	SEAL COVER	1						0
046	191-32970-20	IDLE SPONGE 25L	1						0
		C17-05 MUFFLER							0
033	737-01700-20	MUFFLER GASKET	1						0
050	704-0174C-90	MUFFLER SET	1						0
051	717-01740-80	MUFFLER BODY B COMP.	1						0
052	724-01709-20	MUFFLER FITTING METAL	1						0
053	739-01709-20	MUFFLER JOINT GASKET	1						0
054	716-01709-80	MUFFLER BODY A COMP.	1						0
056	990-11050-401	SCREW 5X40	2						0
057	992-01050-011	WASHER 5	2						0
		C17-06 FUEL/OIL FILTER							0
001	505-32710-20	OIL PIPE B	1						0
002	680-04019-21	CLIP 7	3						0
003	992-01050-011	WASHER 5	1						0
004	487-32712-20	OIL FILTER	1						0
005	486-32710-90	OIL FILTER BODY ASS'Y	1						0
006	490-32910-20	THROTTLE ROD	1						0
007	491-32710-20	THROTTLE GUIDE	1						0
011	442-25143-80	PRIMING PUMP COMP.	1						0
014	700-02504-04	FUEL PIPE 2.5X4X42	1						0
016	678-01740-20	RUBBER PIPE	1						0
017	675-11600-90	PUMP FILTER BODY ASS'Y	1						0
021	700-02504-15	FUEL PIPE 2.5X4X150	1						0
022	534-32710-20	RETURN GROMMET	1						0
026	999-67018-000	O-RING P-18	1						0
028	190-3290G-20	ADJUSTER CAP	1						0
029	707-32710-20	GROMMET	1						0
030	704-32710-80	CHOKE BUTTON COMP.	1						0
031	191-32710-20	GROMMET	1						0
032	999-67020-000	O-RING P-20	1						0
040	642-32719-90	OIL TANK CAP ASS'Y	1						0
042	635-32911-90	TANK CAP ASS'Y	1						0
		C17-07 RECOIL STARTER							0
001	756-0174G-90	RECOIL STARTER ASS'Y OR	1						0
002	112-0174G-80	FAN CASE COMP. OR	1						0
003	785-07085-20	STARTER HANDLE	1						0
004	783-07085-20	RECOIL ROPE	1						0
005	780-07085-20	RECOIL SPRING	1						0
006	778-0174F-90	SPRING CASE ASS'Y	1						0
007	774-0174F-20	STARTER PULLY	1						0
008	182-07085-20	SPECIAL WASHER 5.2X15	1						0

ITEM N°	CODE N°	DESCRIPTION	N° Used	x	x	x	x	x	x
		<b>MODEL : CS 30EG(S)</b>							0
009	990-72050-144	TAPPING SCREW 5X14	1						0
010	990-72045-204	TAPPING SCREW 4.5X20	4						0
011	145-01743-20	AIR DEFLECTOR	1						0
		C17-08 CARBURETOR							0
002	578-25007-20	INLET SCREEN	1						0
003	575-25006-20	PUMP BODY	1						0
004	514-25001-20	SET SCREW	1						0
005	577-25007-20	PUMP GASKET	1						0
006	576-25006-20	PUMP DIAPHRAGM	1						0
009	473-25001-20	VALVE HINGE	1						0
010	546-25001-20	HINGE PIN SET SCREW	1						0
011	477-25088-20	VALVE SPRING	1						0
012	605-25001-20	HINGE PIN	1						0
013	476-25004-20	DIAPHRAGM COVER	1						0
014	474-25001-80	METERING DIAPHRAGM COMP. #	1						0
015	475-25038-20	DIAPHRAGM GASKET	1						0
016	603-25012-20	NEEDLE VALVE #	1						0
021	463-25006-20	IDLE ADJUST SPRING	1						0
022	462-25016-20	IDLE ADJUST SCREW	1						0
025	548-25012-20	SET SCREW	4						0
		C17-09 OIL PUMP							0
008	994-16050-141	SCREW 5X14/WS	2						0
011	097-32900-20	OIL PUMP COVER	1						0
012	515-32710-20	OIL PIPE A	1						0
013	084-32900-20	SCREW GEAR	1						0
014	567-01700-20	AIR VENT SPONGE	1						0
015	144-32902-90	OIL PUMP ASS'Y	1						0
016	488-32710-21	OIL ADJUST GROMMET	1						0
017	501-32710-21	OIL PUMP ADJUSTER	1						0
018	999-67006-000	O-RING P-6	1						0
019	088-3277A-91	OIL PUMP CASE SET, SPARE	1						0
020	999-67006-000	O-RING P-6	1						0
036	990-72050-144	TAPPING SCREW 5X14	1						0
038	700-07105-02	VINYL PIPE 7X10.5X20	1						0
039	125-32710-20	CHAIN CATCHER	1						0
042	990-75045-144	TAPPING SCREW 4.5X14	2						0
		C17-10 CLUTCH/CHAIN BRAKE							0
002	121-32530-20	CHAIN BAR CLAMP NUT	1						0
004	287-01700-81	CLUTCH COMP.	1						0
005	999-62101-301	NEEDLE BRG 101310 1.5X7.5	1						0
006	310-32710-20	CLUTCH HOUSING	1						0
007	358-04050-20	CLUTCH WASHER	1						0
021	345-01700-20	CLUTCH SHOE	2						0
022	346-01700-20	CLUTCH BOSS	1						0
023	342-01700-20	CLUTCH SPRING	2						0
024	348-01700-21	CLUTCH PLATE A	2						0
025	992-74004-143	RIVET 4X14	2						0
031	993-41040-101	SCREW 4X10	1						0
032	461-32908-20	GUIDE PLATE A	1						0
037	511-32900-20	CRANK SHAFT COLLAR 7.7	1						0
045	993-41040-101	SCREW 4X10	1						0
046	040-32911-91	SIDE CASE ASS'Y	1						0
047	462-32911-20	GUIDE PLATE B	1						0
048	993-30026-050	SCREW 2.6X5	1						0
049	365-32911-80	BRAKE HANDLE, BLACK	1						0
050	116-32911-80	TENSIONER BOLT COMP.	1						0



**C17-01 CS30EG(S) CYLINDER/PISTON/CRANK SHAFT**

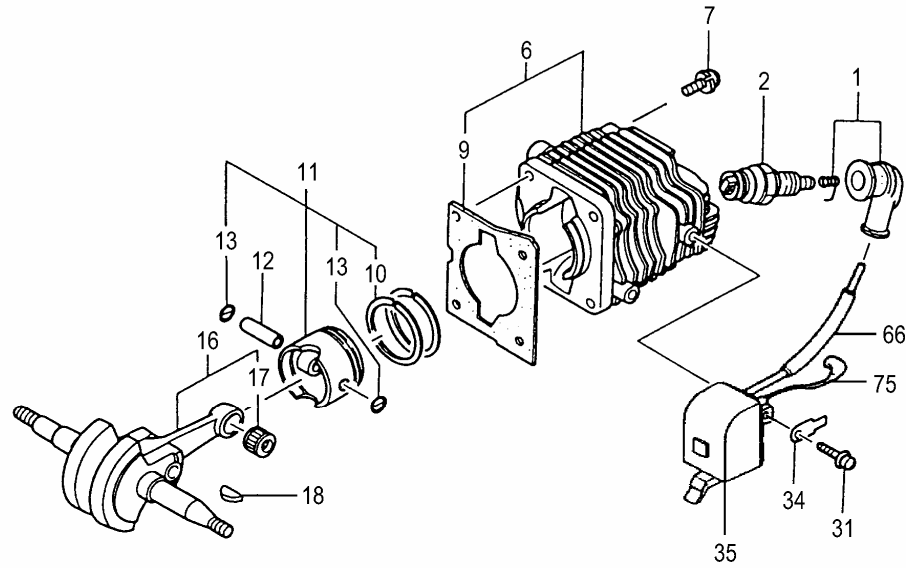

REF. NUMBER	PARTS NUMBER	DESCRIPTION	Q'TY	SERIAL NUMBER
001	157-11666-90	SPARK PLUG CAP ASS'Y	1	
002	018-00562-20	SPARK PLUG RCJ-8	1	
006	001-01740-91	CYLINDER SET	1	
007	994-61050-164	HEX. HOLE BOLT 5X16S	4	
009	017-01740-20	CYLINDER GASKET	1	
010	041-01730-20	PISTON RING	2	
011	030-01741-90	PISTON SET	1	
012	037-01400-20	PISTON PIN	1	
013	039-00000-20	PISTON PIN CIRCLIP	2	
016	046-01740-80	CRANK SHAFT COMP.	1	
017	999-62091-325	NEEDLE BRG F-910 1.4X8.5	1	
018	068-10100-20	WOOD-RUFF KEY 3X13X4.5	1	
031	994-16040-186	HIGH TENSION SCREW 4X18WS	2	
034	205-01700-20	TAB	1	
035	167-21540-80	IGNITION COIL COMP.	1	
066	755-32050-20	CORD INSULATOR TUBE	1	
075	178-01740-80	CORD, B 70M	1	

**C17-02**

**CS30EG(S) CRANK CASE**

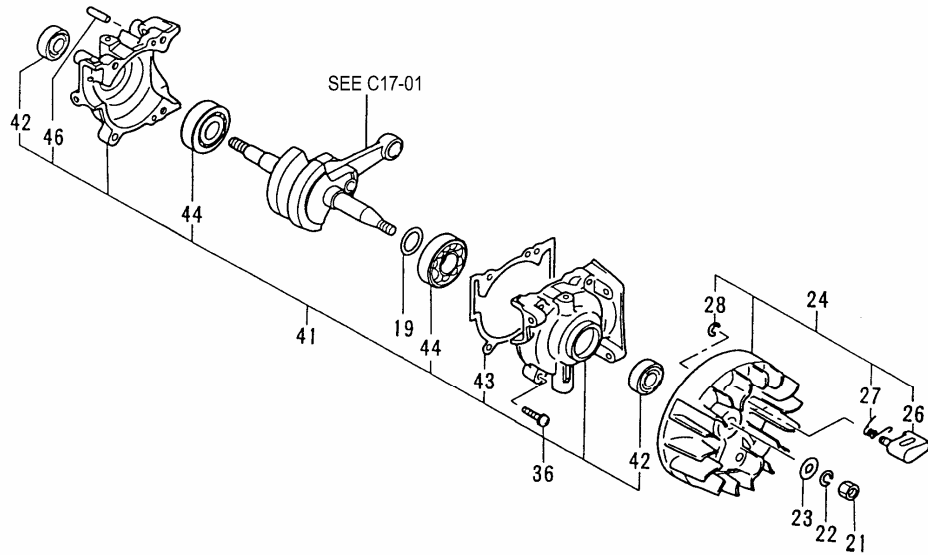

REF. NUMBER	PARTS NUMBER	DESCRIPTION	Q'TY	SERIAL NUMBER
019	071-04063-21	SHIM 0.1	V	
019	071-04063-23	SHIM 0.2	V	
019	071-04063-24	SHIM 0.3	V	
019	071-04063-25	SHIM 0.4	V	
021	066-00000-20	FLYWHEEL NUT 12	1	
022	992-10070-012	S.WASHER 7	1	
023	992-01070-011	WASHER 7	1	
024	155-21540-90	MAGNETO ROTOR ASS'Y	1	
026	788-01740-20	STARTER PAWL	2	
027	790-01740-20	STARTER PAWL SPRING	2	
028	993-55040-001	STOP RING	2	
036	994-61050-204	HEX. HOLE BOLT 5X20/S	4	
041	072-01740-94	CRANK CASE ASS'Y	1	
042	999-66122-200	OIL SEAL TB 12227	2	
043	090-0174G-20	CRANK CASE GASKET	1	
044	999-61620-106	BALL BEARING 6201 A2C3,32MM/OD	2	
046	999-05250-980	NEEDLE ROLLER 2.5X9.8	1	

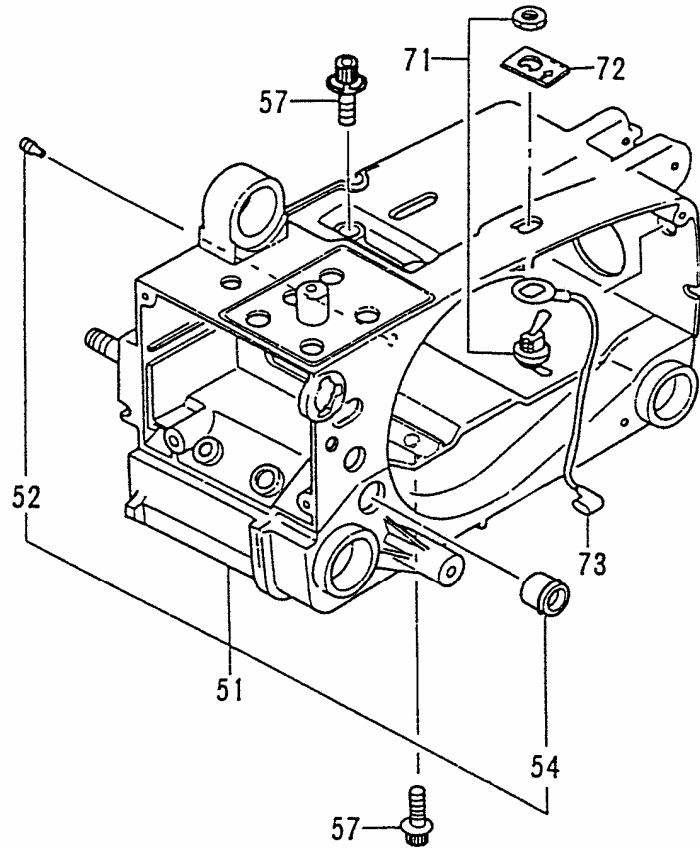
**C17-03****CS30EG(S) ENGINE CASE**

REF. NUMBER	PARTS NUMBER	DESCRIPTION	Q'TY	SERIAL NUMBER
051	560-32942-90	ENGINE CASE ASS'Y, VERMILION	1	
052	562-04060-20	AIR VENT VALVE B	1	
054	645-01750-90	AIR VENT VALVE SET	1	
057	994-63050-204	HEX.HOLE BOLT 5X20PS	4	
071	162-01570-90	STOP SWITCH ASS'Y	1	
072	183-01300-20	SWITCH NAME PLATE	1	
073	274-01700-80	EARTH CORD COMP.	1	

**C17-04 CS30EG(S) AIR CLEANER**

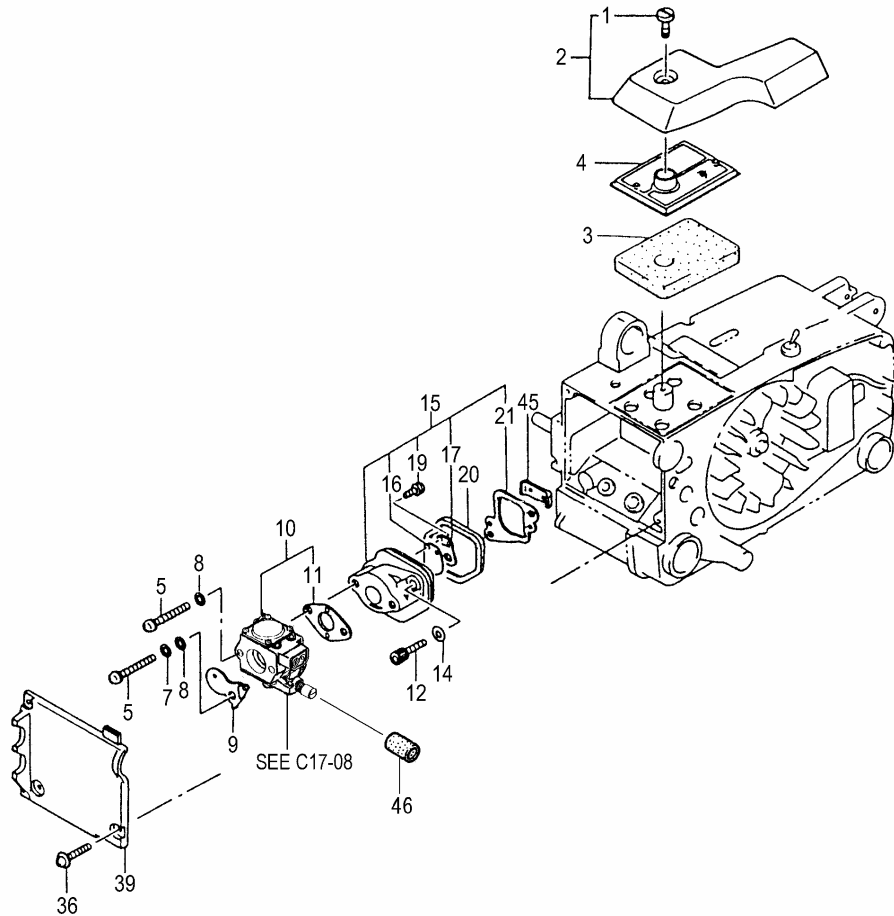

REF. NUMBER	PARTS NUMBER	DESCRIPTION	Q'TY	SERIAL NUMBER
001	380-0631A-20	CLEANER COVER BOLT	1	
002	051-3291J-91	CLEANER COVER	1	
003	446-01740-20	AIRCLEANER SPONGE	1	
004	420-01740-80	AIRCLEANER ELEMENT COMP.	1	
005	994-14050-451	SCREW 5X45S	2	
007	992-00050-011	SMALL WASHER 5	1	
008	708-32350-20	CHOKE SHIM 0.8	2	
009	700-32918-20	CHOKE VALVE	1	
010	455-32947-90	CARBURETOR SET,WT-760	1	
011	402-01740-20	CARBURETOR GASKET	1	
012	994-61050-204	HEX. HOLE BOLT 5X20/S	2	
014	992-00050-011	SMALL WASHER 5	2	
015	404-0174G-90	INSULATOR SET	1	
016	394-0174G-20	REED VALVE	1	
017	395-0174G-20	VALVE HOLDER	1	
019	990-15030-121	BINDING HEAD SCREW 3X12	2	
020	409-01700-20	CARBURETOR INSULATOR RUBBER	1	
021	403-0174G-20	INSULATOR GASKET	1	
036	990-75045-144	TAPPING SCREW 4.5X14	3	
039	152-3290J-21	AIRCLEANER COVER B	1	
045	129-01730-20	SEAL COVER	1	
046	191-32970-20	IDLE SPONGE 25L	1	

**C17-05**

**CS30EG(S) MUFFLER**

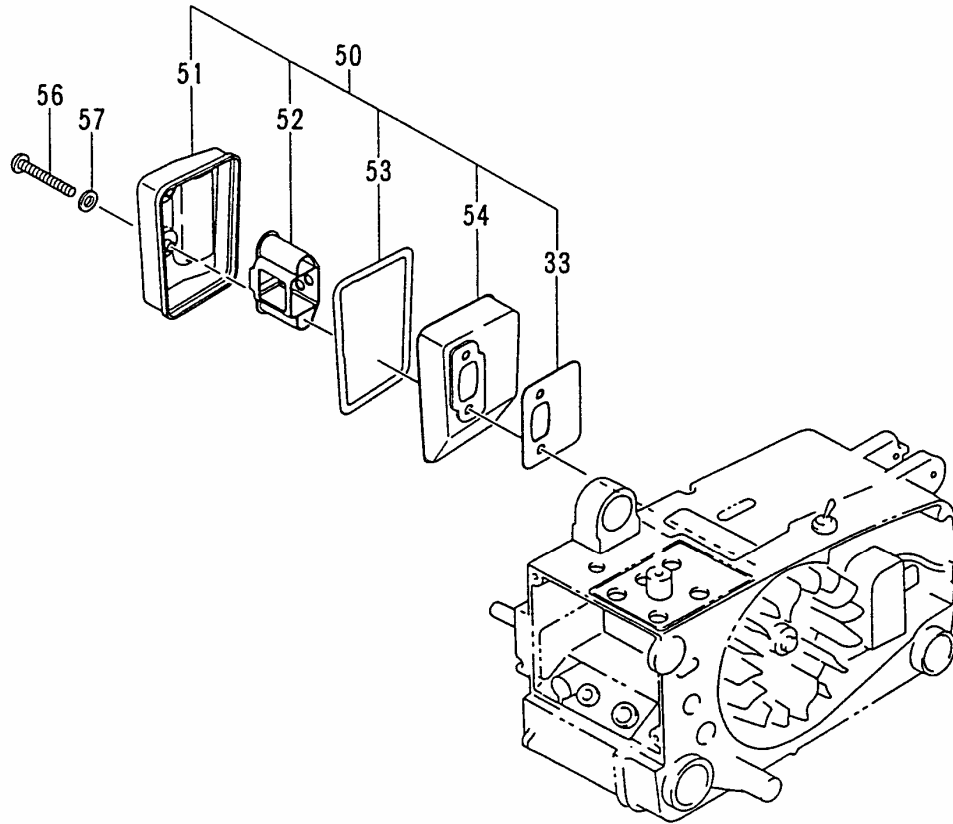

REF. NUMBER	PARTS NUMBER	DESCRIPTION	Q'TY	SERIAL NUMBER
033	737-01700-20	MUFFLER GASKET	1	
050	704-0174C-90	MUFFLER SET	1	
051	717-01740-80	MUFFLER BODY B COMP.	1	
052	724-01709-20	MUFFLER FITTING METAL	1	
053	739-01709-20	MUFFLER JOINT GASKET	1	
054	716-01709-80	MUFFLER BODY A COMP.	1	
056	990-11050-401	SCREW 5X40	2	
057	992-01050-011	WASHER 5	2	

**C17-06**

**CS30EG(S) FUEL/OIL FILTER**

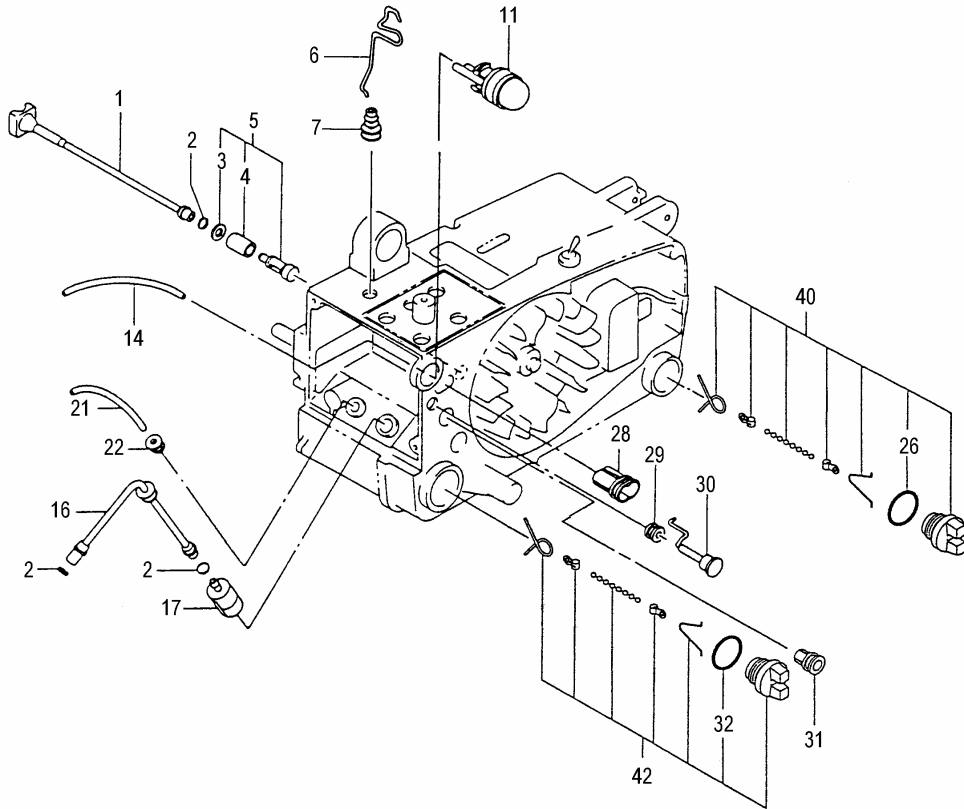

REF. NUMBER	PARTS NUMBER	DESCRIPTION	Q'TY	SERIAL NUMBER
001	505-32710-20	OIL PIPE B	1	
002	680-04019-21	CLIP 7	3	
003	992-01050-011	WASHER 5	1	
004	487-32712-20	OIL FILTER	1	
005	486-32710-90	OIL FILTER BODY ASS'Y	1	
006	490-32910-20	THROTTLE ROD	1	
007	491-32710-20	THROTTLE GUIDE	1	
011	442-25143-80	PRIMING PUMP COMP.	1	
014	700-02504-04	FUEL PIPE 2.5X4X42	1	
016	678-01740-20	RUBBER PIPE	1	
017	675-11600-90	PUMP FILTER BODY ASS'Y	1	
021	700-02504-15	FUEL PIPE 2.5X4X150	1	
022	534-32710-20	RETURN GROMMET	1	
026	999-67018-000	O-RING P-18	1	
028	190-3290G-20	ADJUSTER CAP	1	
029	707-32710-20	GROMMET	1	
030	704-32710-80	CHOKE BUTTON COMP.	1	
031	191-32710-20	GROMMET	1	
032	999-67020-000	O-RING P-20	1	
040	642-32719-90	OIL TANK CAP ASS'Y	1	
042	635-32911-90	TANK CAP ASS'Y	1	

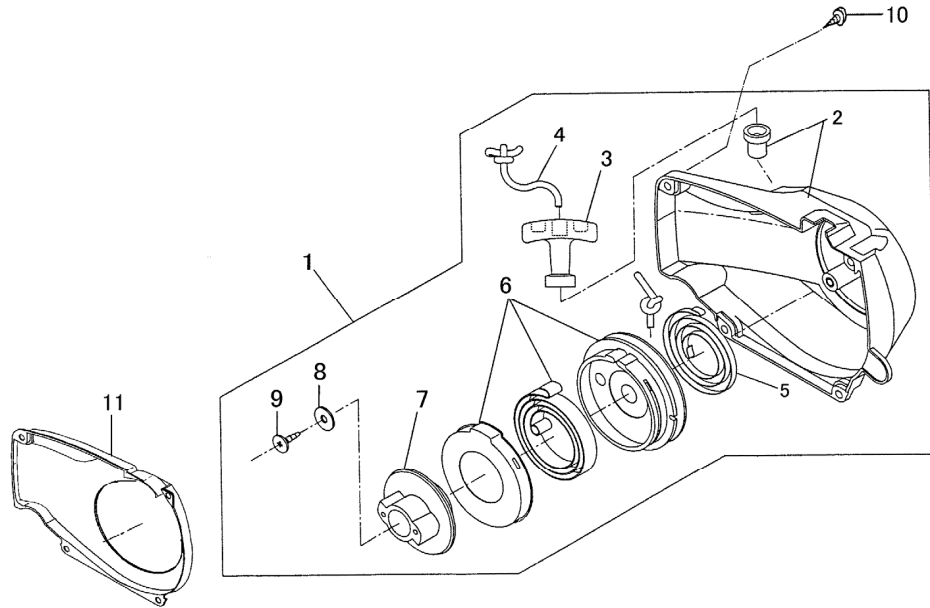
**C17-07****CS30EG(S) RECOIL STARTER**

REF. NUMBER	PARTS NUMBER	DESCRIPTION	Q'TY	SERIAL NUMBER
001	756-0174G-90	RECOIL STARTER ASSY OR	1	
002	112-0174G-80	FAN CASE COMP. OR	1	
003	785-07085-20	STARTER HANDLE	1	
004	783-07085-20	RECOIL ROPE	1	
005	780-07085-20	RECOIL SPRING	1	
006	778-0174F-90	SPRING CASE ASS'Y	1	
007	774-0174F-20	STARTER PULLY	1	
008	182-07085-20	SPECIAL WASHER 5.2X15	1	
009	990-72050-144	TAPPING SCREW 5X14	1	
010	990-72045-204	TAPPING SCREW 4.5X20	4	
011	145-01743-20	AIR DEFLECTOR	1	

**C17-08**

**CS30EG(S) CARBURETOR**

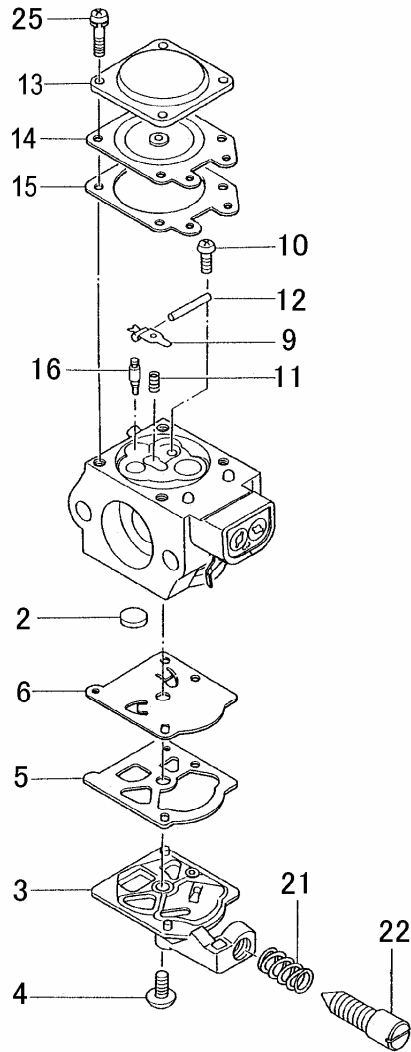

REF. NUMBER	PARTS NUMBER	DESCRIPTION	Q'TY	SERIAL NUMBER
002	578-25007-20	INLET SCREEN	1	
003	575-25006-20	PUMP BODY	1	
004	514-25001-20	SET SCREW	1	
005	577-25007-20	PUMP GASKET	1	
006	576-25006-20	PUMP DIAPHRAGM	1	
009	473-25001-20	VALVE HINGE	1	
010	546-25001-20	HINGE PIN SET SCREW	1	
011	477-25088-20	VALVE SPRING	1	
012	605-25001-20	HINGE PIN	1	
013	476-25004-20	DIAPHRAGM COVER	1	
014	474-25001-80	METERING DIAPHRAGM COMP. #	1	
015	475-25038-20	DIAPHRAGM GASKET	1	
016	603-25012-20	NEEDLE VALVE #	1	
021	463-25006-20	IDLE ADJUST SPRING	1	
022	462-25016-20	IDLE ADJUST SCREW	1	
025	548-25012-20	SET SCREW	4	

**C17-09**

**CS30EG(S) OIL PUMP**

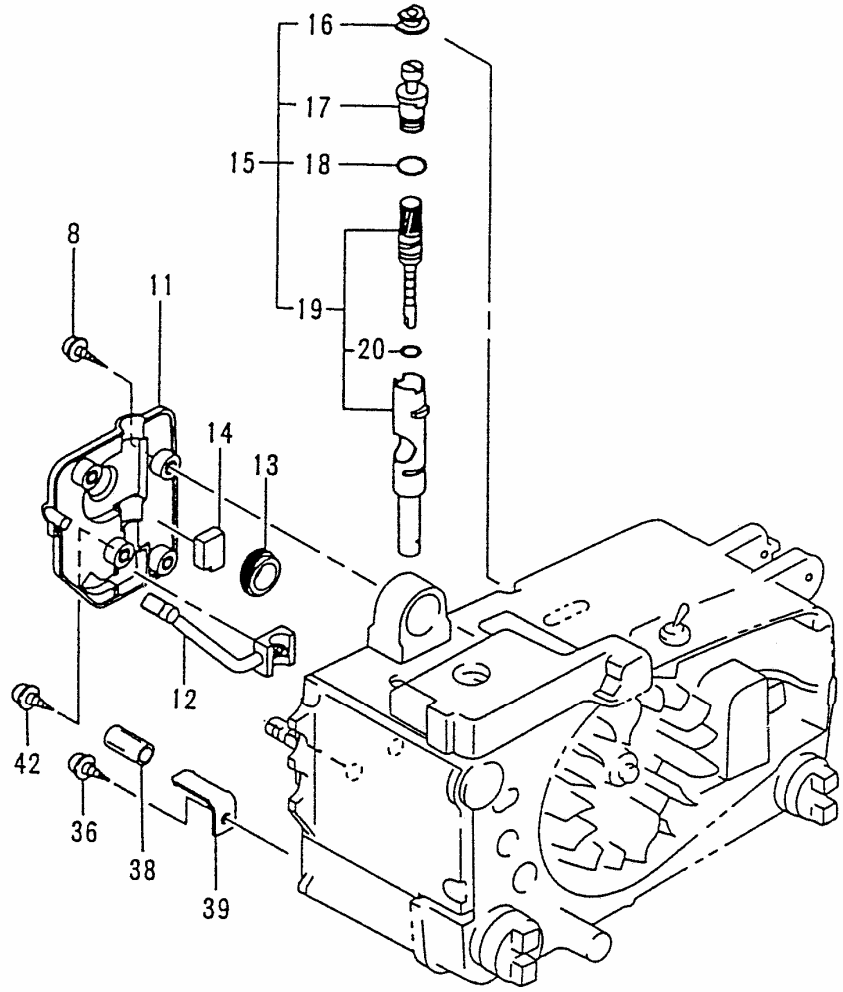

REF. NUMBER	PARTS NUMBER	DESCRIPTION	Q'TY	SERIAL NUMBER
008	994-16050-141	SCREW 5X14/WS	2	
011	097-32900-20	OIL PUMP COVER	1	
012	515-32710-20	OIL PIPE A	1	
013	084-32900-20	SCREW GEAR	1	
014	567-01700-20	AIR VENT SPONGE	1	
015	144-32902-90	OIL PUMP ASS'Y	1	
016	488-32710-21	OIL ADJUST GROMMET	1	
017	501-32710-21	OIL PUMP ADJUSTER	1	
018	999-67006-000	O-RING P-6	1	
019	088-3277A-91	OIL PUMP CASE SET, SPARE	1	
020	999-67006-000	O-RING P-6	1	
036	990-72050-144	TAPPING SCREW 5X14	1	
038	700-07105-02	VINYL PIPE 7X10.5X20	1	
039	125-32710-20	CHAIN CATCHER	1	
042	990-75045-144	TAPPING SCREW 4.5X14	2	

**C17-10**

**CS30EG(S) CLUTCH/CHAIN BRAKE**

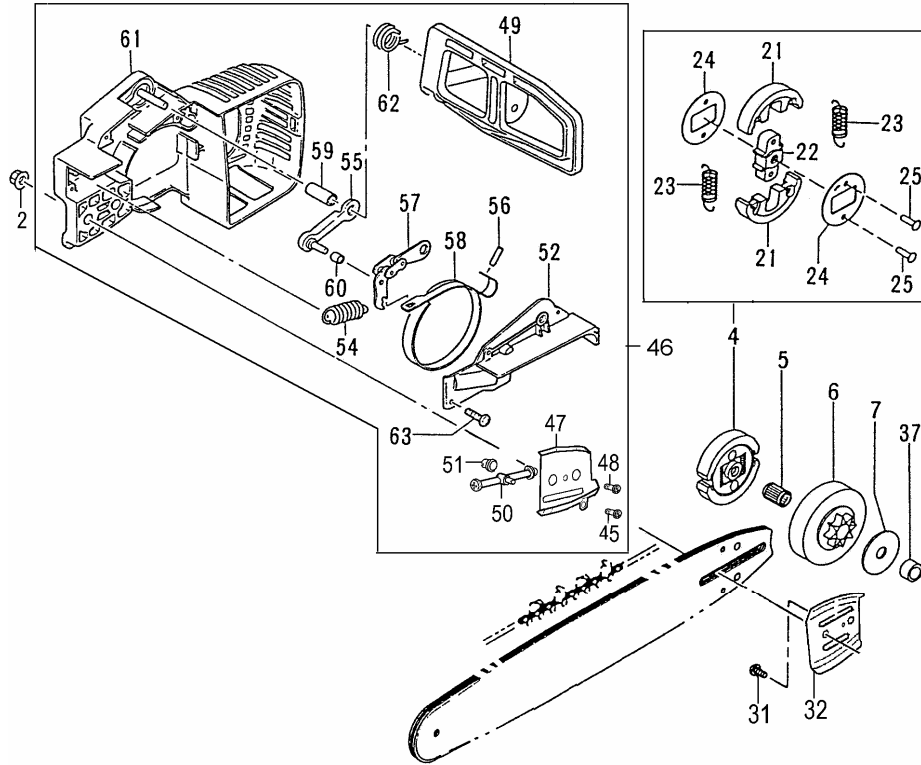

REF. NUMBER	PARTS NUMBER	DESCRIPTION	Q'TY	SERIAL NUMBER
002	121-32530-20	CHAIN BAR CLAMP NUT	1	
004	287-01700-81	CLUTCH COMP.	1	
005	999-62101-301	NEEDLE BRG 101310 1.5X7.5	1	
006	310-32710-20	CLUTCH HOUSING	1	
007	358-04050-20	CLUTCH WASHER	1	
021	345-01700-20	CLUTCH SHOE	2	
022	346-01700-20	CLUTCH BOSS	1	
023	342-01700-20	CLUTCH SPRING	2	
024	348-01700-21	CLUTCH PLATE A	2	
025	992-74004-143	RIVET 4X14	2	
031	993-41040-101	SCREW 4X10	1	
032	461-32908-20	GUIDE PLATE A	1	
037	511-32900-20	CRANK SHAFT COLLAR 7.7	1	
045	993-41040-101	SCREW 4X10	1	
046	040-32911-91	SIDE CASE ASS'Y	1	
047	462-32911-20	GUIDE PLATE B	1	
048	993-30026-050	SCREW 2.6X5	1	
049	365-32911-80	BRAKE HANDLE, BLACK	1	
050	116-32911-80	TENSIONER BOLT COMP.	1	
051	301-72000-20	GEAR A	1	
052	375-32900-21	BRAKE LINK COVER, BLACK	1	
054	374-32900-20	BRAKE SPRING	1	
055	386-32901-80	BRAKE LINK SUPPORT COMP.	1	
056	999-05300-980	NEEDLE ROLLER 3X9.8	1	
057	379-32901-80	BRAKE LINK COMP.	1	
058	378-3291R-20	BRAKE BAND	1	
059	470-10246-20	CLEANER FIXING COLLAR	1	
060	031-32901-20	COLLAR 7	1	
061	039-32901-81	SIDE CASE COMP.	1	
062	388-32900-20	BLAKE LEVER SPRING	1	
063	993-41040-151	HI-LO SCREW 4X15	3	

**C17-11 CS30EG(S) HANDLE**

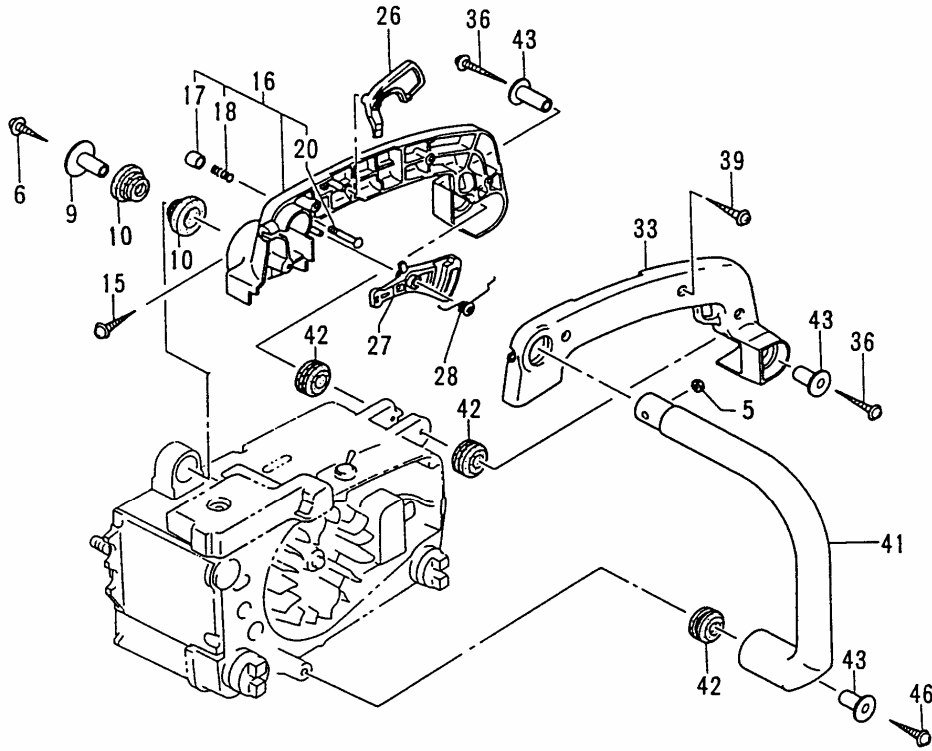

REF. NUMBER	PARTS NUMBER	DESCRIPTION	Q'TY	SERIAL NUMBER
005	991-78040-010	NYLON LOCK NUT 4	1	
006	990-73050-404	TAPPING SCREW 5X40	1	
009	275-32710-20	DAMPER COLLAR A	1	
010	219-32750-20	DAMPER A	2	
015	994-15040-302	SCREW 4X30PS	1	
016	011-32900-80	REAR HANDLE B COMP.	1	
017	725-32161-20	PUSH PIN CAP	1	
018	066-32300-20	STOPPER SPRING	1	
020	064-32530-20	PUSH PIN	1	
026	257-32910-20	SAFETY LEVER	1	
027	060-32910-20	THROTTLE LEVER	1	
028	061-32710-20	THROTTLE LEVER SPRING	1	
033	010-32900-20	REAR HANDLE A	1	
036	990-73050-354	TAPPING SCREW 5X35	2	
039	993-41040-151	HI-LO SCREW 4X15	3	
041	209-32946-20	FRONT HANDLE	1	
042	266-32750-20	DAMPER B	3	
043	276-32710-20	DAMPER COLLAR B	3	
046	990-73050-354	TAPPING SCREW 5X35	1	

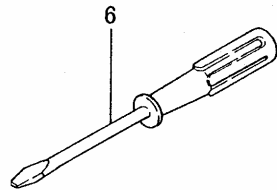
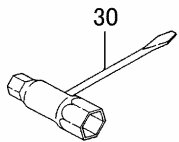
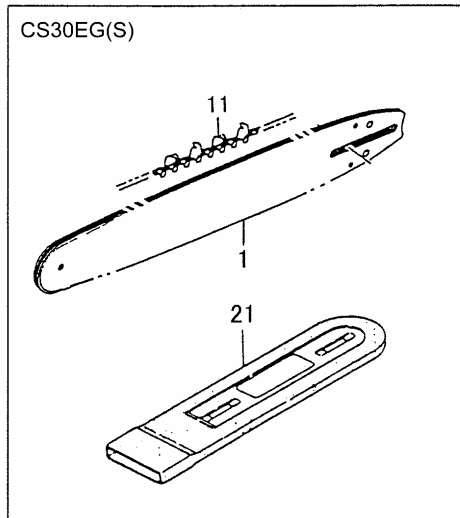
**C17-12****CS30EG(S) COVER/CHAIN/CHAIN BAR**

REF. NUMBER	PARTS NUMBER	DESCRIPTION	Q'TY	SERIAL NUMBER
001	109-72900-20	CHAIN BAR 12	1	
006	081-29329-7U	4X50 MINUS DRIVER	1	
011	128-32911-20	CHAIN 12 X3/8 ,	1	
021	943-32713-20	CHAIN COVER 12	1	
030	013-29323-50	COMBI. BOX SPANNER 10X19	1	

**C17-13**

**CS30EG(S) LABELS**

REF. NUMBER	PARTS NUMBER	DESCRIPTION	Q'TY	SERIAL NUMBER
001	906-72900-20	NAME PLATE CS30EG(S)	1	
005	915-07182-20	STARTER MARK	1	
010	909-32946-21	CAUTION MARK A(ECS)	1	

