

ITEM N°	CODE N°	DESCRIPTION	N° Used	x	x	x	x	x	x	x
		MODEL : DW 25EF (SRP)								0
009	577-25292-20	PUMP GASKET	1							0
010	599-2001W-38	LONG MAIN JET #38	1							0
011	550-25100-20	O-RING	1							0
012	489-25100-20	STOP RING	1							0
013	539-25120-20	SWIVEL	1							0
015	514-25100-20	THROTTLE SET SCREW	2							0
016	544-25164-20	CABLE ADJUSTER STAY	1							0
019	431-0634C-20	CLEANER PACKING	1							0
020	548-25151-20	SET SCREW	4							0
021	549-25165-20	THRUST WASHER	1							0
201	578-25007-20	INLET SCREEN	1							0
		S45-07 GEAR CASE								0
001	002-32141-20	GEAR CASE A	1							0
002	006-3210A-80	GEAR CASE B COMP.	1							0
004	089-32141-80	SHIFT FORK COMP.	1							0
005	106-32141-20	SHIFT GUIDE SPRING	1							0
006	108-32141-20	SHIFT LEVER	1							0
007	300-32250-80	GREASE NIPPLE COMP.	1							0
008	673-35600-20	STEEL BALL	1							0
009	990-51040-083	HEX. HOLE BOLT 4X8	1							0
010	992-01040-011	WASHER 4	1							0
011	999-05041-203	KNOCK PIN 4X12	2							0
012	999-62091-211	NEEDLE BRG TLA912 1.5X5.8	1							0
014	018-32192-20	GEAR 4	1							0
015	999-61720-221	BALL BEARING #7202B, 35MM/OD	1							0
016	040-32120-20	WASHAER C 5.0	1							0
017	999-61620-202	BALL BEARING #6202Z, 35MM/OD	1							0
018	993-51035-002	STOP RING C-35, INNER	1							0
019	068-01006-20	WOOD-RUFF KEY 3X13X5	1							0
020	022-32183-20	DRIVE SHAFT	1							0
026	994-14050-181	SCREW 5X18/S	4							0
031	060-32141-20	FORWARD GEAR	1							0
032	140-32141-20	THRUST WASHER 2	1							0
033	993-57200-002	STOP RING 20, INNER	1							0
034	999-05061-200	NEEDLE ROLLER 6X18	3							0
041	992-09350-030	WAVE WASHER B.B 35	1							0
043	141-32141-20	THRUST WASHER 0.8	1							0
044	059-32141-20	IDLE GEAR	1							0
045	999-62091-211	NEEDLE BRG TLA912 1.5X5.8	1							0
046	062-32141-20	INPUT SHAFT	1							0
047	141-32141-20	THRUST WASHER 0.8	1							0
049	993-51024-002	STOP RING C-24, INNER	1							0
050	993-55080-001	E TYPE STOP RING 8	1							0
052	999-61609-002	BALL BEARING 609Z ST	1							0
053	058-32141-20	IDLE SHAFT	1							0
060	061-32141-20	REVERSE GEAR	1							0
061	999-62091-211	NEEDLE BRG TLA912 1.5X5.8	1							0
062	063-32192-20	COUNTER SHAFT	1							0
104	993-50013-002	STOP RING C-13, OUTER	1							0
		S45-08 OPERATION PIPE/LEVER								0
003	226-32141-80	CLUTCH HOUSING COMP.	1							0
011	999-05041-203	KNOCK PIN 4X12	2							0
022	990-23060-301	PLUS BOLT 6X30	2							0
024	992-10060-012	S.WASHER 6	2							0

S45-01

DW25EF(SRP) CYLINDER/PISTON/CRANK SHAFT

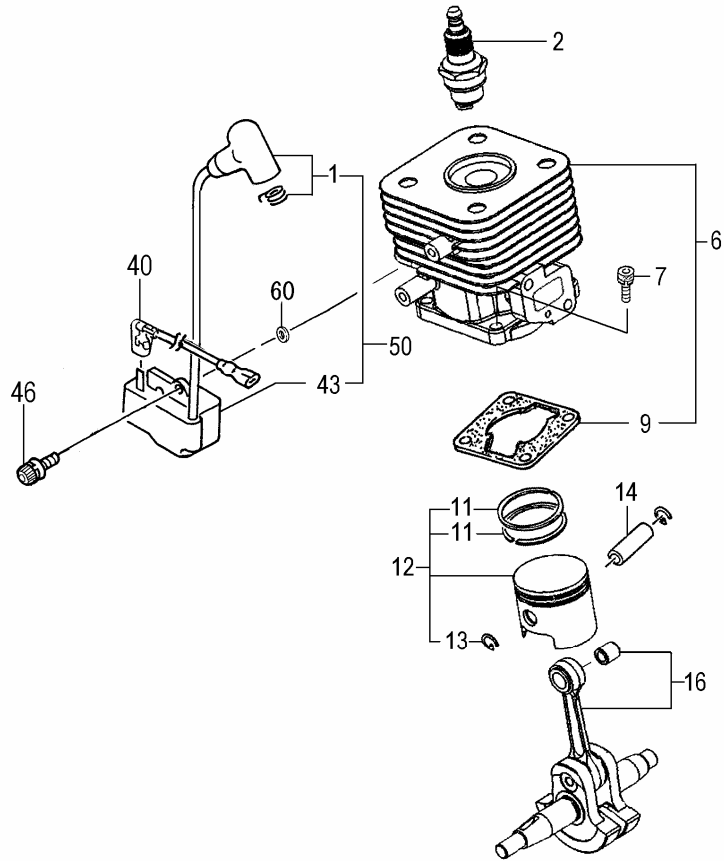

REF. NUMBER	PARTS NUMBER	DESCRIPTION	Q'TY	SERIAL NUMBER
001	157-01680-90	PLUG CAP ASS'Y	1	
002	018-00562-20	SPARK PLUG RCJ-8	1	
006	001-0740A-90	CYLINDER SET	1	
007	994-61050-184	HEX. HOLE BOLT 5X18/S	4	
009	017-07355-20	CYLINDER GASKET T=1.0	1	
011	041-01700-20	PISTON RING	2	
012	030-07350-90	PISTON SET	1	
013	039-00601-20	PISTON PIN CIRCLIP	2	
014	037-07045-20	PISTON PIN	1	
016	046-07350-82	CRANK SHAFT COMP.	1	
040	178-01680-80	STOP CORD B 190M	1	
043	167-21014-80	IGNITION COIL COMP.	1	
046	994-64040-184	HEX. HOLE BOLT 4X18WS	2	
050	167-21015-90	IGNITION COIL ASS'Y MB66	1	
060	182-0186A-20	WASHER	2	

S45-02

DW25EF(SRP) CRANK CASE

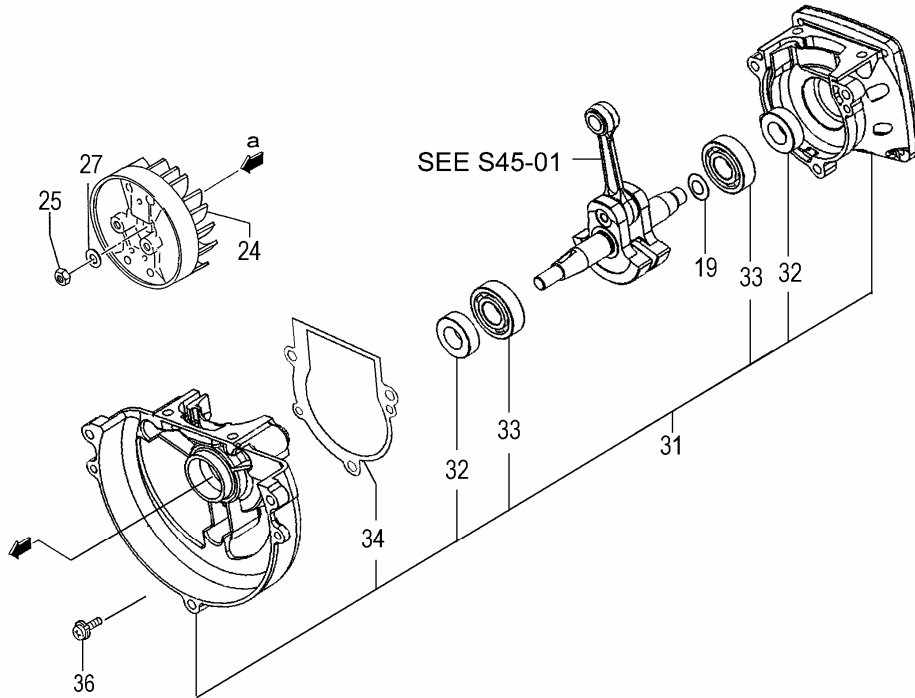

REF. NUMBER	PARTS NUMBER	DESCRIPTION	Q'TY	SERIAL NUMBER
019	330-00200-23	GEAR SHAFT SHIM 0.20	V	
019	330-00200-24	GEAR SHAFT SHIM 0.30	V	
024	155-21014-80	MAGUET RITIR COMB. FW-	1	
025	991-01080-011	HEX. NUT 8	1	
027	992-01080-011	WASHER 8	1	
031	072-03045-94	CRANK CASE ASSY	1	
032	999-66122-200	OIL SEAL TB 12227	2	
033	999-61600-115	BALL BEARING 6001 C3	2	
034	090-07350-22	CRANK CASE GASKET	1	
036	994-61050-164	HEX. HOLE BOLT 5X16S	4	

S45-03

DW25EF(SRP) ENGINE-1

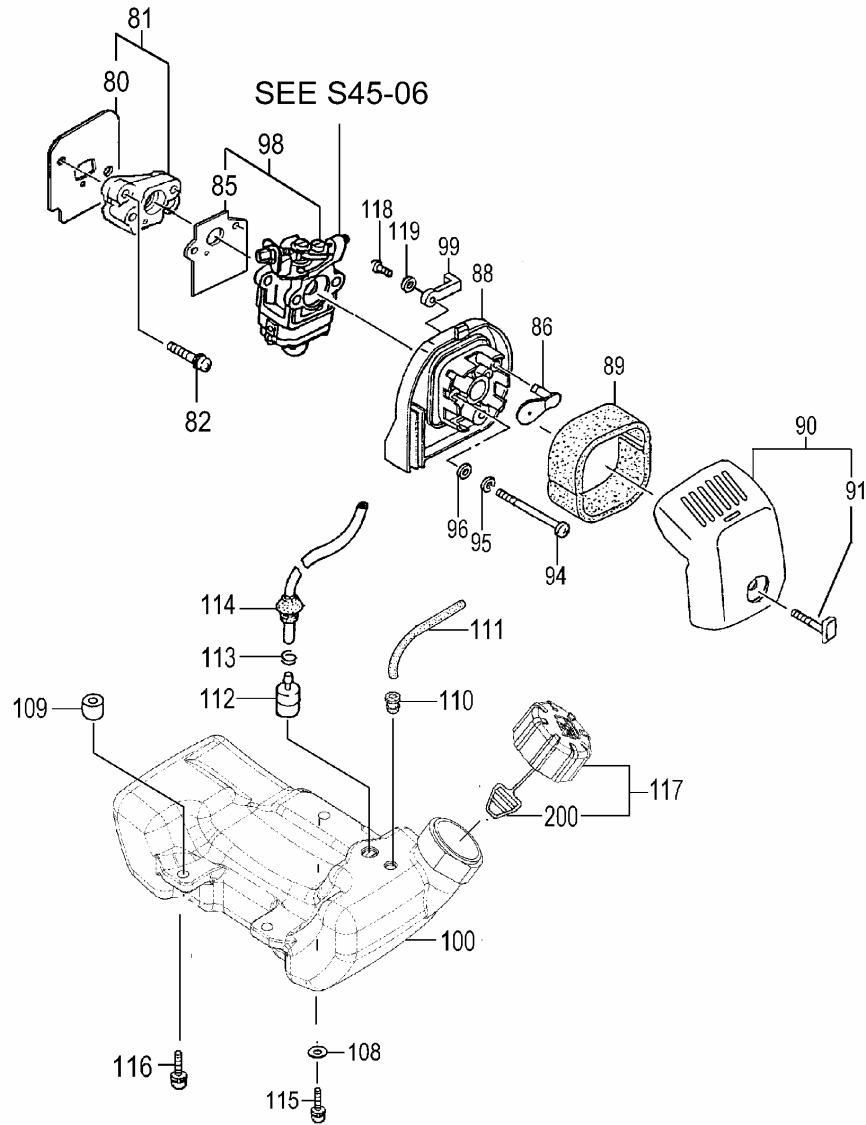

REF. NUMBER	PARTS NUMBER	DESCRIPTION	Q'TY	SERIAL NUMBER
080	403-07020-21	INLET MANIFOLD GASKET	1	
081	404-07020-91	INSULATOR SET	1	
082	994-64050-254	HEX. HOLE BOLT 5X25WS	2	
085	402-0656A-20	CARBURETOR GASKET	1	
086	528-0652N-22	CHOKE PLATE 2.0	1	
088	423-0652N-80	CLEANER BODY COMP.	1	
089	446-0652N-20	CLEANER SPONGE	1	
090	452-03046-90	CLEANER COVER ASS'Y	1	
091	450-07024-80	COVER FIXING BOLT	1	
094	990-11050-552	SCREW 5X55	2	
095	992-10050-012	S.WASHER 5	2	
096	992-00050-011	SMALL WASHER 5	2	
098	455-0740A-90	CABURETOR SET WYJ-463	1	
099	523-0652N-20	CHOKE CONTROL LEVER	1	
100	591-07355-22	TANK ORANGE	1	
109	659-00801-20	COLLAR 5.8	3	
110	534-32710-20	RETURN GROMMET	1	
111	700-03005-06	FUEL PIPE 3X5X60	1	
112	675-04042-80	PUMP FILTER BODY COMP.	1	
113	680-00731-20	CLIP, 6.3 DIA.	1	
114	223-0097A-90	FUEL PIPE ASS'Y	1	
115	994-63050-205	HEX HOLE BOLT 5X20PS	1	
116	994-63050-164	HEX.HOLE BOLT 5X16/PS	2	
117	595-01690-90	TANK CAP ASS'Y (BLACK)	1	
118	993-49040-142	TAP SCREW 4X14 P	1	
119	992-01040-011	WASHER 4	1	
200	626-32550-20	TANK CAP CHAIN	1	

S45-04 DW25EF(SRP) ENGINE-2

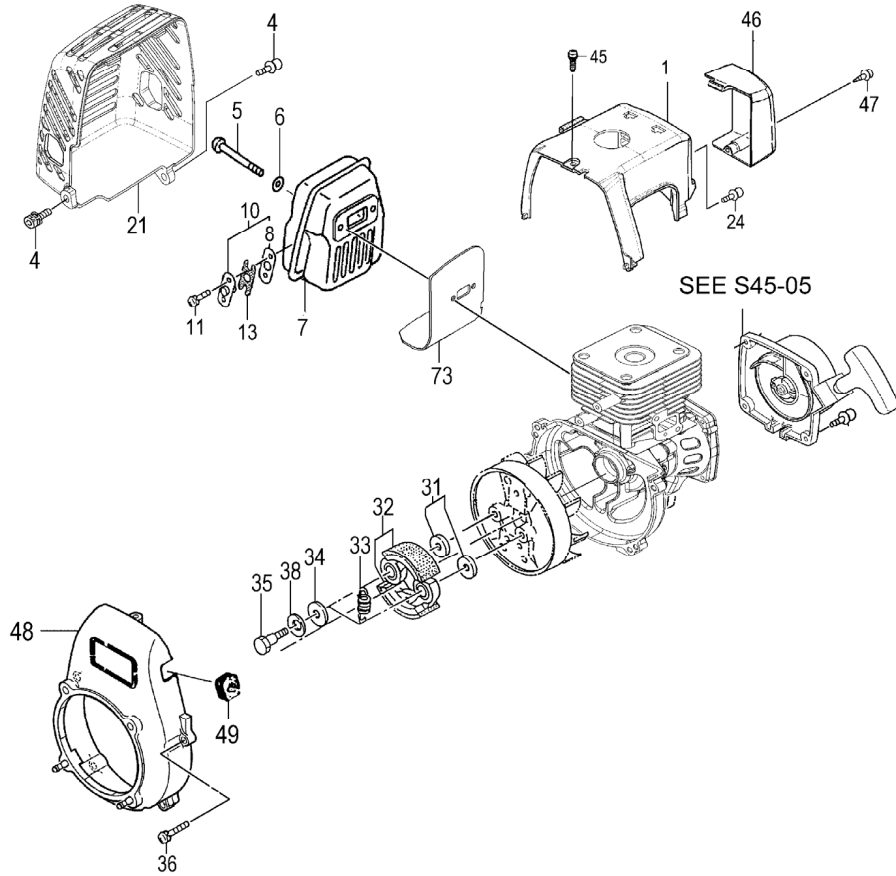

REF. NUMBER	PARTS NUMBER	DESCRIPTION	Q'TY	SERIAL NUMBER
001	016-07500-20	CYLINDER COVER (BLK)	1	
004	994-63050-164	HEX.HOLE BOLT 5X16/PS	2	
005	990-51060-653	HEX.HOLE BOLT 6X65	2	
006	992-01060-011	WASHER 6	2	
007	706-0740A-80	MUFFLER COMP.	1	
008	751-06500-20	MUFFLER SPECIAL GASKET	1	
010	734-0740A-90	TAIL PIPE SET	1	
011	994-36040-081	SCREW 4X8/WS	2	
013	732-0740A-20	SPARK ARRESTER	1	
021	738-0740A-80	MUFFLER PROTECTOR COMP.	1	
024	994-64040-185	HEX. HOLE BOLT 4X18/WS	2	
031	359-02103-20	CLUTCH WASHER B	2	
032	290-01620-80	CLUTCH SHOE COMP.	2	
033	342-0630B-20	CLUTCH SPRING	1	
034	348-0630A-20	CLUTCH PLATE A 0.5	2	
035	357-0075T-20	STEP BOLT	2	
036	994-64050-184	HEX.HOLE BOLT 5X18/WS	3	
038	992-05080-030	BENT WASHER 8	2	
045	994-63040-154	HEX.HOLE BOLT 4X15/PS	1	
046	132-0740A-20	AIR DEFLECTOR BLK	1	
047	993-48040-142	TAPPING SCREW 4X14	1	
048	112-0736F-80	FAN CASE COMP OR	1	
049	203-11660-20	PRIMARY CORD GROMMET	1	
073	133-07500-20	HEAT SHIELD	1	

S45-05

DW25EF(SRP) RECOIL STARTER

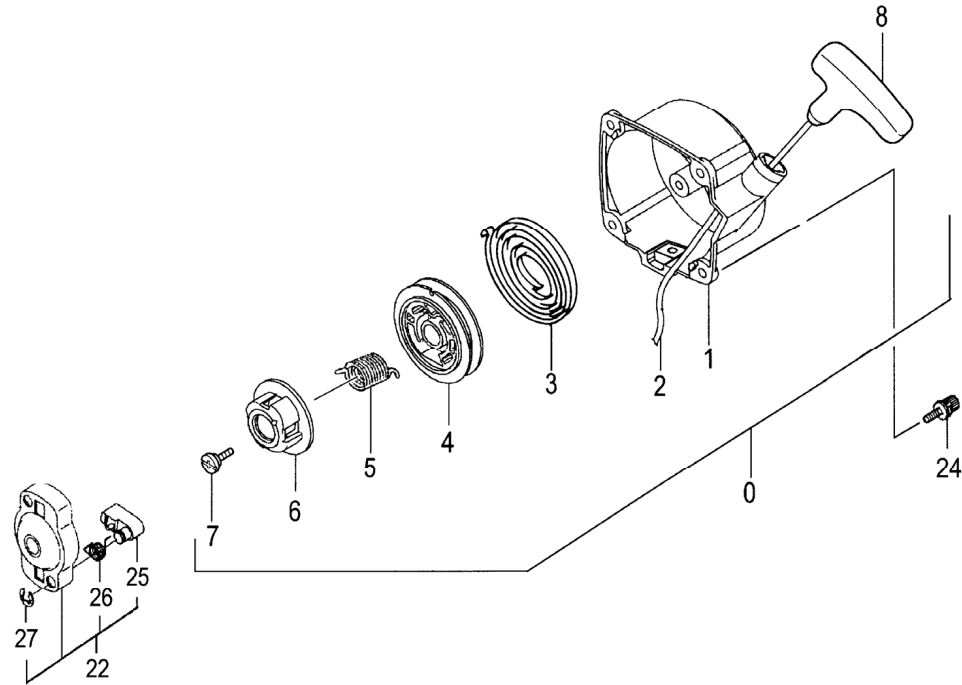

REF. NUMBER	PARTS NUMBER	DESCRIPTION	Q'TY	SERIAL NUMBER
000	762-07350-90	RECOIL STARTER BODY ASS'Y	1	
001	772-07350-80	RECOIL STARTER BODY COMP	1	
002	783-0720F-20	STARTER ROPE 3.5X860	1	
003	780-06097-20	RECOIL SPRING	1	
004	774-0720F-20	STARTER ROPE REEL	1	
005	758-0651H-20	DUMPER SPRING	1	
006	759-0651H-20	CAM PLATE	1	
007	839-03045-20	SET SCREW	1	
008	785-03045-20	STARTER HANDLE	1	
022	798-0651H-90	STARTER PULLEY ASS'Y	1	
024	994-64040-185	HEX. HOLE BOLT 4X18WS	2	
025	788-0651H-20	STARTER PAWL	2	
026	790-06097-20	STARTER PAWL SPRING	2	
027	993-55050-000	STOP RING E-5	2	

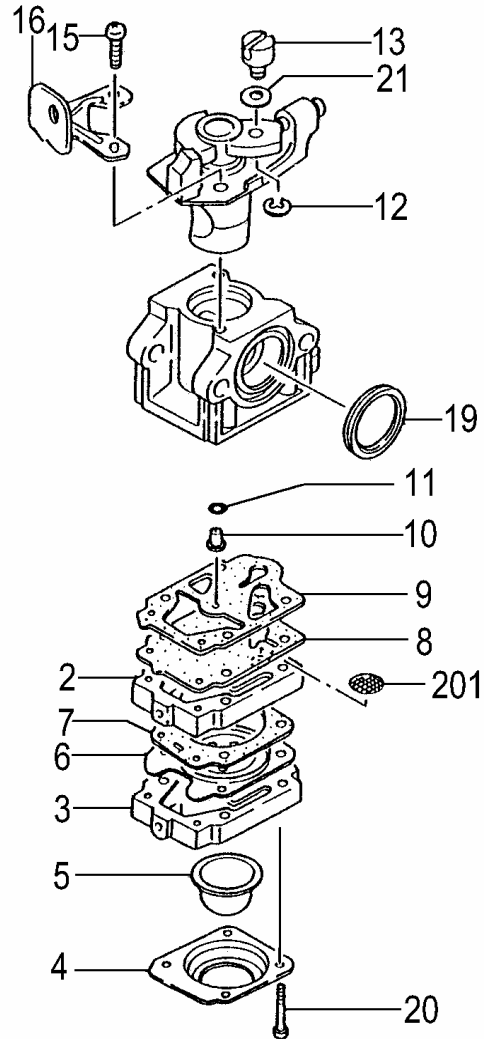
S45-06**DW25EF(SRP) CARBURETOR**

REF. NUMBER	PARTS NUMBER	DESCRIPTION	Q'TY	SERIAL NUMBER
002	575-25153-80	PUMP BODY COMP	1	
003	442-25151-80	PRIMING PUMP COMP.	1	
004	476-25151-20	DIAPHRAGM COVER	1	
005	447-25108-20	PRIMING BODY	1	
006	474-25601-20	METERING DIAPHRAGM	1	
007	475-25153-20	DIAPHRAGM GASKET	1	
008	576-25100-20	PUMP DIAPHRAGM	1	
009	577-25292-20	PUMP GASKET	1	
010	599-2001W-38	LONG MAIN JET #38	1	
011	550-25100-20	O-RING	1	
012	489-25100-20	STOP RING	1	
013	539-25120-20	SWIVEL	1	
015	514-25100-20	THROTTLE SET SCREW	2	
016	544-25164-20	CABLE ADJUSTER STAY	1	
019	431-0634C-20	CLEANER PACKING	1	
020	548-25151-20	SET SCREW	4	
021	549-25165-20	THRUST WASHER	1	
201	578-25007-20	INLET SCREEN	1	

S45-07

DW25EF(SRP) GEAR CASE

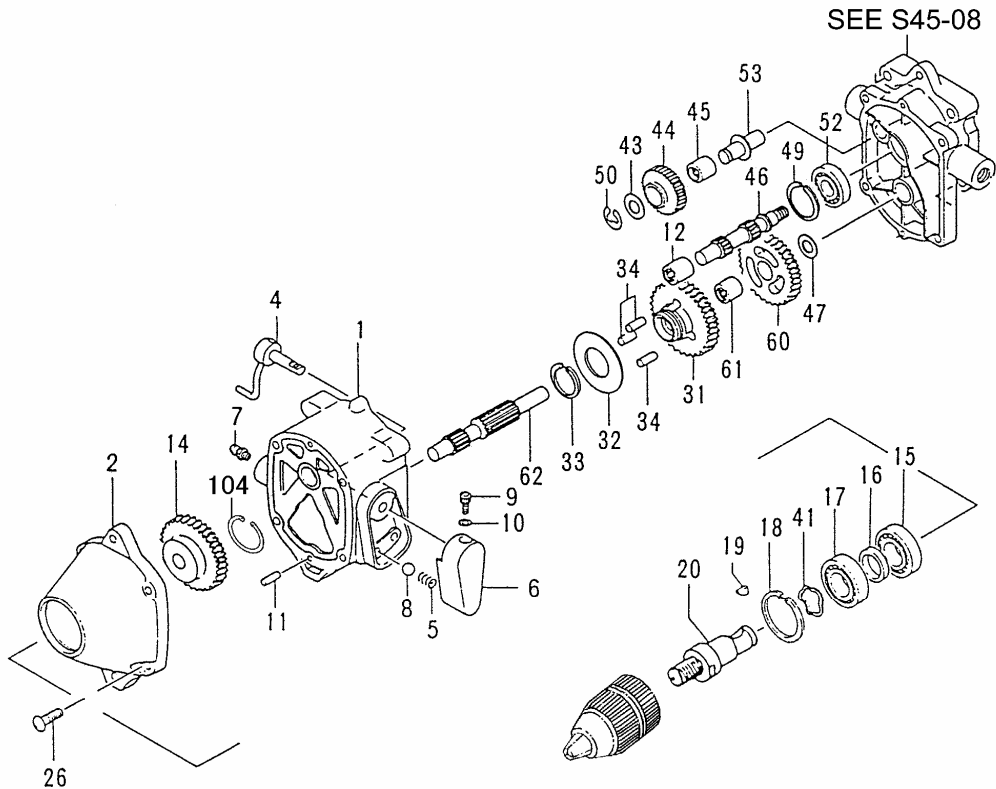

REF. NUMBER	PARTS NUMBER	DESCRIPTION	Q'TY	SERIAL NUMBER
001	002-32141-20	GEAR CASE A	1	
002	006-3210A-80	GEAR CASE B COMP.	1	
004	089-32141-80	SHIFT FORK COMP.	1	
005	106-32141-20	SHIFT GUIDE SPRING	1	
006	108-32141-20	SHIFT LEVER	1	
007	300-32250-80	GREASE NIPPLE COMP.	1	
008	673-35600-20	STEEL BALL	1	
009	990-51040-083	HEX. HOLE BOLT 4X8	1	
010	992-01040-011	WASHER 4	1	
011	999-05041-203	KNOCK PIN 4X12	2	
012	999-62091-211	NEEDLE BRG TLA912 1.5X5.8	1	
014	018-32192-20	GEAR 4	1	
015	999-61720-221	BALL BEARING #7202B, 35MM/1.375X1.375X0.375	1	
016	040-32120-20	WASHAER C 5.0	1	
017	999-61620-202	BALL BEARING #6202Z, 35MM/1.375X1.375X0.375	1	
018	993-51035-002	STOP RING C-35, INNER	1	
019	068-01006-20	WOOD-RUFF KEY 3X13X5	1	
020	022-32183-20	DRIVE SHAFT	1	
026	994-14050-181	SCREW 5X18/S	4	
031	060-32141-20	FORWARD GEAR	1	
032	140-32141-20	THRUST WASHER 2	1	
033	993-57200-002	STOP RING 20, INNER	1	
034	999-05061-200	NEEDLE ROLLER 6X18	3	
041	992-09350-030	WAVE WASHER B.B 35	1	
043	141-32141-20	THRUST WASHER 0.8	1	
044	059-32141-20	IDLE GEAR	1	
045	999-62091-211	NEEDLE BRG TLA912 1.5X5.8	1	
046	062-32141-20	INPUT SHAFT	1	
047	141-32141-20	THRUST WASHER 0.8	1	
049	993-51024-002	STOP RING C-24, INNER	1	
050	993-55080-001	E TYPE STOP RING 8	1	
052	999-61609-002	BALL BEARING 609Z ST	1	
053	058-32141-20	IDLE SHAFT	1	
060	061-32141-20	REVERSE GEAR	1	
061	999-62091-211	NEEDLE BRG TLA912 1.5X5.8	1	
062	063-32192-20	COUNTER SHAFT	1	
104	993-50013-002	STOP RING C-13, OUTER	1	

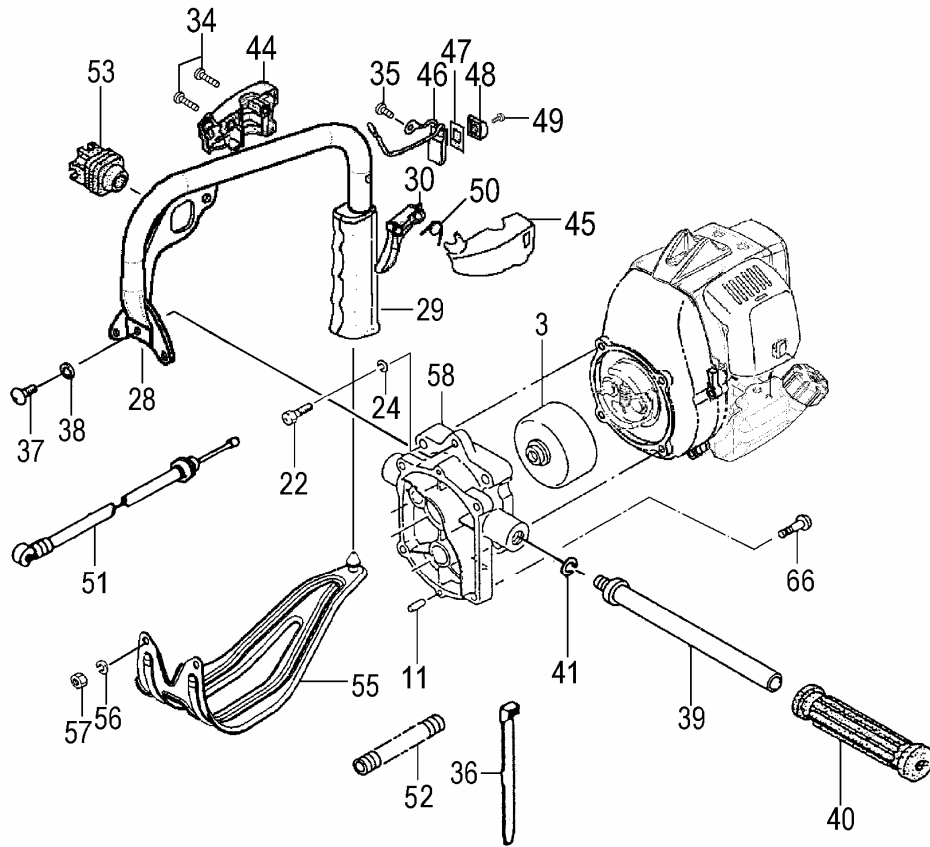
S45-08**DW25EF(SRP) OPERATION PIPE/LEVER**

REF. NUMBER	PARTS NUMBER	DESCRIPTION	Q'TY	SERIAL NUMBER
003	226-32141-80	CLUTCH HOUSING COMP.	1	
011	999-05041-203	KNOCK PIN 4X12	2	
022	990-23060-301	PLUS BOLT 6X30	2	
024	992-10060-012	S.WASHER 6	2	
028	258-71020-80	HANDLE A COMP	1	
029	165-33130-20	HANDLE GRIP A	1	
030	060-71020-20	THROTTLE LEVER	1	
034	993-49040-142	TAP SCREW 4X14 P	2	
035	990-11040-061	SCREW 4X6	1	
036	198-33130-20	CORD CLAMP	2	
037	990-23060-161	PLUS BOLT 6X16	1	
038	992-10060-012	S.WASHER 6	1	
039	259-3210A-80	HANDLE COMP. B	1	
040	055-32130-20	HANDLE GRIP	1	
041	992-10100-012	S.WASHER 10	1	
044	884-71020-20	THROTTLE BODY B	1	
045	875-71020-20	THROTTLE BODY A	1	
046	170-71020-80	STOP SWITCH COMP.	1	
047	925-33160-20	STOP BUTTON MARK	1	
048	258-11650-20	BUTTON STOP	1	
049	994-31030-101	SCREW 3X10	1	
050	061-71020-20	THROTTLE LEVER SPRING	1	
051	885-71021-80	THROTTLE WIRE 400+30	1	
052	164-07034-50	PROTECTION TUBE 345L	1	
053	155-3210A-20	CHUCK HANDLE HOLDER	1	
055	265-71000-80	HANDLE SUPPORT COMP.	1	
056	992-10060-012	S.WASHER 6	2	
057	991-01060-011	NUT 6	2	
058	150-32141-80	CLUTCH CASE COMP.	1	
066	994-14050-181	SCREW 5X18/S	4	

S45-09

DW25EF(SRP) TOOLS/OPTIONAL PARTS

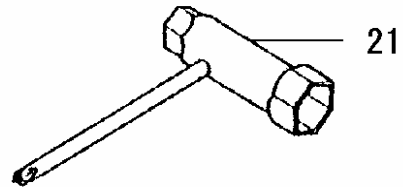
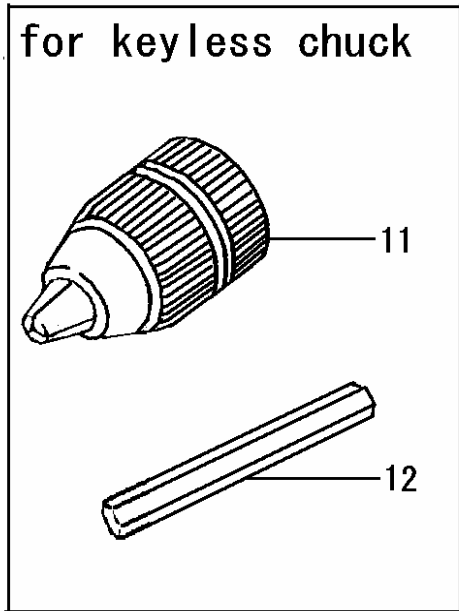

REF. NUMBER	PARTS NUMBER	DESCRIPTION	Q'TY	SERIAL NUMBER
011	060-32170-81	KEYLESS CHACK	1	
012	100-29710-02	LOCKING BAR	1	
015	076-71020-20	ADAPTER (FOR LEFT HAND)	1	
021	036-29710-10	COMBI BOX PLUS	1	

S45-10

DW25EF(SRP) LABELS

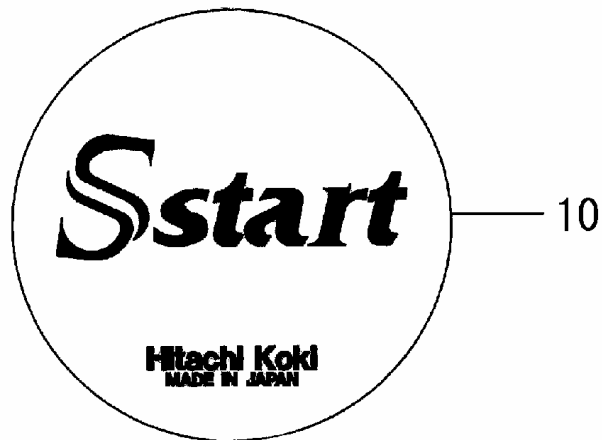
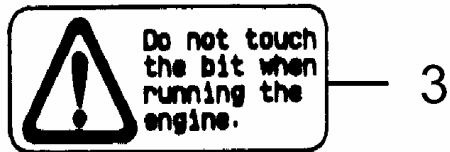

REF. NUMBER	PARTS NUMBER	DESCRIPTION	Q'TY	SERIAL NUMBER
001	929-0740L-20	SYMBOL MARK DW25EF(SRP)	1	
003	921-32172-20	CAUTION MARK	1	
010	915-07366-21	STARER MARK S- START	1	